

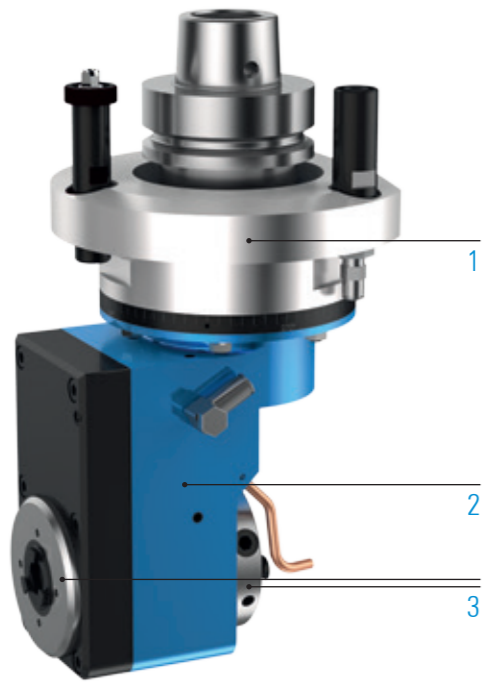



LOCK RECESS TRIMMING UNIT - CLASSIC LINE FORTE

TECHNICAL DATA

Lubrication	Grease
Max. drive speed n_2	15,000rpm
Transmission ratio ($n_1: n_2$)	1:1.2
Max. drive torque M_2	25Nm
Weight	about 5.5kg



STANDARD DESIGN

- 1  Machine Connection
HSK - F63
- 2  Head length
M
- 3  Output spindle
Centring Ø30/Whistle Notch Ø16/Ø20
+
 Collet chuck ER16A

ADDITIONAL OPTIONS: MODULAR DESIGN

1



MACHINE CONNECTION



 For further information see p. 106

2



HEAD LENGTH





 For further information see p. 107

3

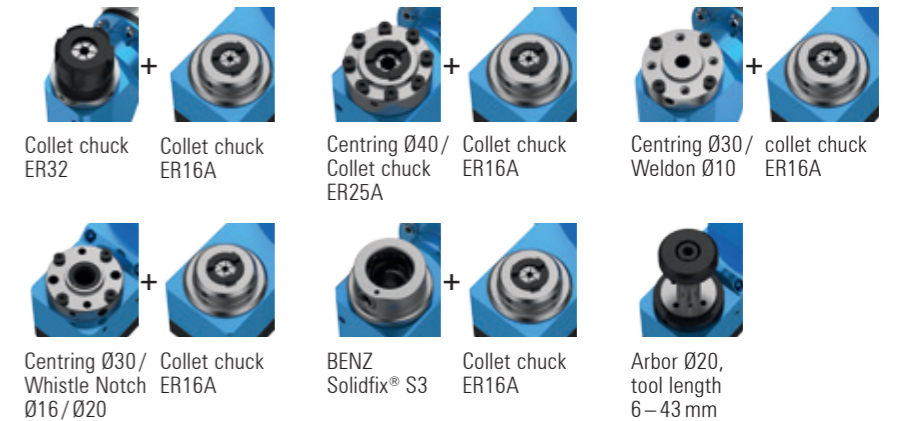

OUTPUT SPINDLE



 For further information see p. 108

MACHINING



Drilling



Milling



Sawing

SPECIFICATIONS

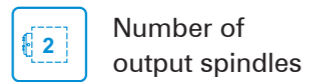

Number of output spindles



Axis angle



C-angle

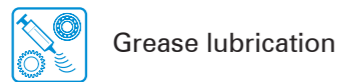

Grease lubrication

VIDEO



Angle head - live in the application
Scan QR code or go to:
www.youtube.com/BENZWerkzeugsysteme

ORDER DIRECTLY



Inquiry form:
www.benz-tools.de/en/products