

BROACHING UNIT FOR LATHES

BENZ LINA 4.0 - FIX

TECHNICAL DATA



TYPE

GS **GSL**
i = 1:1 i = 1:1

L1

GS **GSL**
variable variable

TOOL HOLDER



Prism tool holder
Ø 30 mm

TURRET INTERFACE



VDI



BMT



CDI



More on
request



Broaching
machining



Actuating
angle



Internal +
external
cooling



Star
Turret



Disc
Turret

i.com



For questions regarding BENZ i.com
please contact our BENZ Sales Team.

Performance data

GS	i	EC / IC	IC p _{max} [bar]	n _{1 max} / *n _{2 max} [min ⁻¹]	M _{1 max} / F _{c max} [Nm]	f [mm]	**Groove width _{max} [mm]
Usable working stroke = 32 mm Total Stroke = 34 mm	1:1	✓/✓	50	1500 / 1500	30 / 1700	0,02 - 0,10	12

*double stroke per minute

**depending on the material to be machined

Performance data

GSL	i	EC / IC	IC p _{max} [bar]	n _{1 max} / *n _{2 max} [min ⁻¹]	M _{1 max} / F _{c max} [Nm]	f [mm]	**Groove width _{max} [mm]
Usable working stroke = 51 mm Total Stroke = 53 mm	1:1	✓/✓	50	1000 / 1000	46 / 1700	0,02 - 0,10	12

*double stroke per minute

**depending on the material to be machined

For more information about the product or to order please contact our BENZ Sales Team



please click here ▶

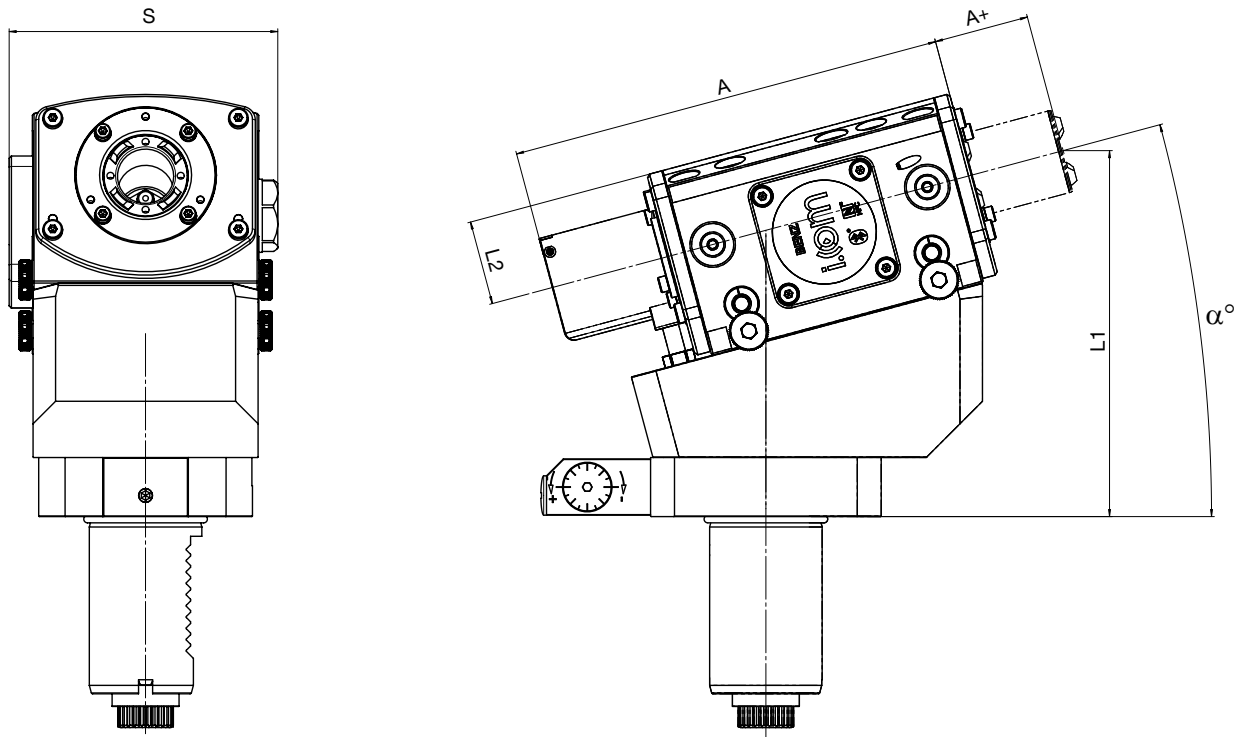

Technical Data

Type	Size Plunger	**A+ [mm]	A [mm]	L1 [mm]	L2 [mm]	α [°]	S [mm]	Weight [kg]*
GS	30	32 / 34	155	■	30	■	95,5	8-9
GSL	30	51 / 53	204	■	30	■	115,5	11-12

■ Dimension depends on machine geometry and specification angle-α

*varies based on base holder

**usable working stroke / total stroke

PRODUCT INFORMATION



www.benztooling.com/en