

BROACHING UNITS FOR TURNING CENTERS

BENZ LINA - AXIAL

▶ PRODUCT IN OVERVIEW

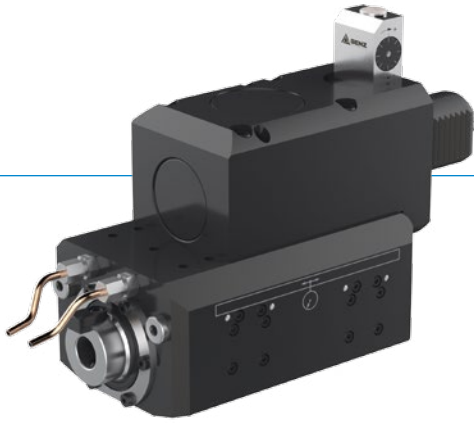

- ▶ **max. groove width** 8-10 mm
- ▶ **Ratio** 1:1
- ▶ **max. feed per stroke** 0.15 mm
- ▶ **max. speed** 1,200 rpm

▶ TYPE

DS **DSS**

▶ TURRET INTERFACE



VDI



More on request

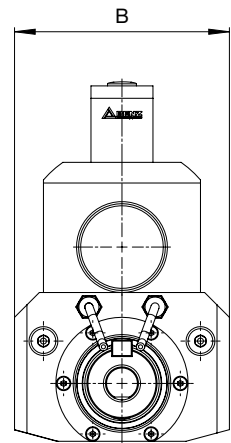
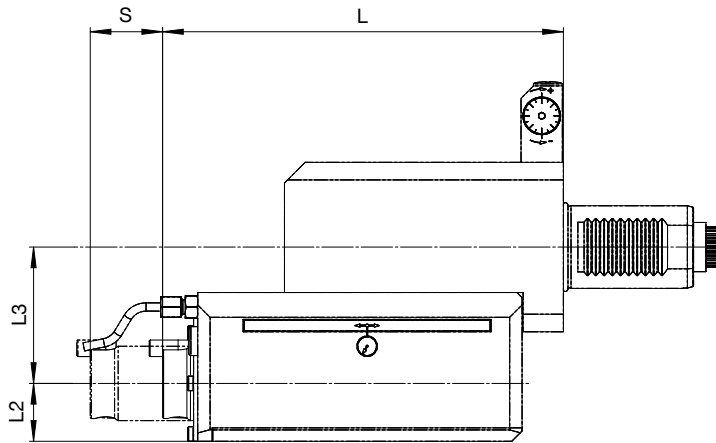

DS	
Usable working stroke	= 32 mm
Total stroke	= 35 mm
Material strength _{max}	= 900 N/mm ²
No. of strokes/speed _{max}	= 1,000 rpm

► **Technical data**

L2 [mm]	L3 [mm]	B [mm]	S [mm]	L [mm]	Weight [kg]
28	66	104	32/35	194	approx. 12

DSS	
Usable working stroke	= 17 mm
Total stroke	= 19 mm
Material strength _{max}	= 1,100 N/mm ²
No. of strokes/speed _{max}	= 1,200 rpm

► **Technical data**

L2 [mm]	L3 [mm]	B [mm]	S [mm]	L [mm]	Weight [kg]
28	66	104	17/19	194	approx. 12