

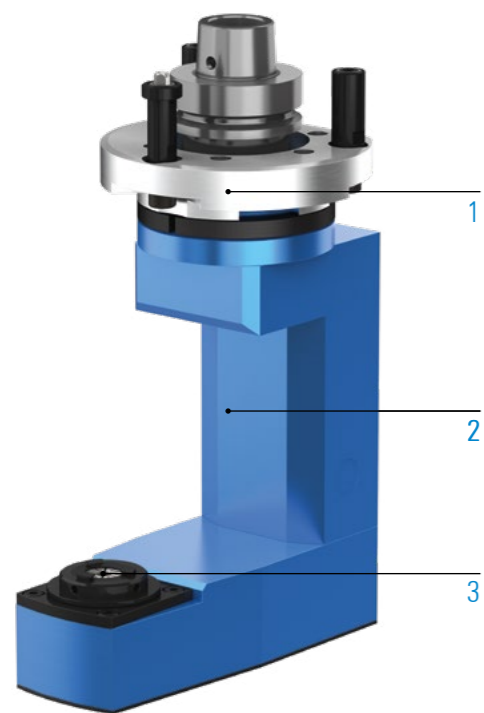

# UNDERSURFACE UNIT – CLASSIC LINE SUBIO

## TECHNICAL DATA

Lubrication Grease  
 Max. drive speed  $n_2$  10,000rpm  
 Transmission ratio ( $n_1: n_2$ ) 1:1  
 Max. drive torque  $M_2$  8Nm  
 Weight about 7 kg

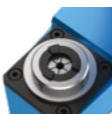

### STANDARD DESIGN

- 1  Machine Connection  
HSK - F63
- 2  Head size  
M
- 3  Output spindle  
Collet chuck  
ER25A

## ADDITIONAL OPTIONS: MODULAR DESIGN

1



### MACHINE CONNECTION



2

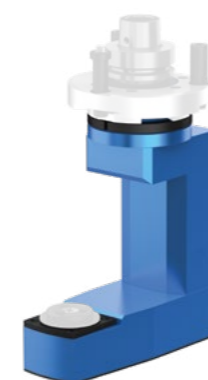

### HEAD SIZE



3



### OUTPUT SPINDLE



Collet chuck  
ER25A

### MACHINING



Drilling



Milling

### SPECIFICATIONS



Number of  
output spindles



Axis angle



C-angle



Grease lubrication

### TECHNICAL DRAWING

