

BLOW NOZZLE UNIT – CLASSIC LINE

SOFFIARO

TECHNICAL DATA

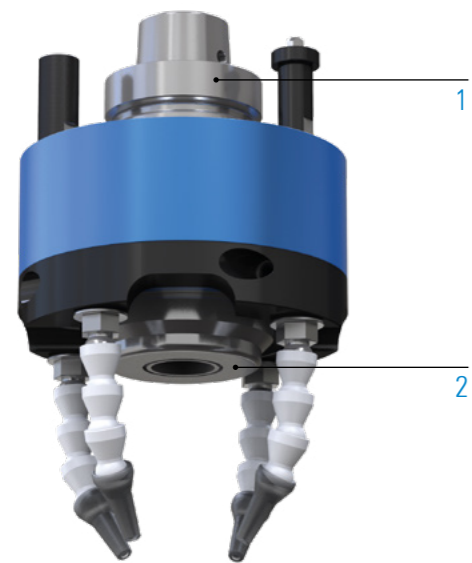

Lubrication
 Max. drive speed n_2
 Transmission ratio ($n_1: n_2$)
 Max. drive torque M_2
 Weight

Grease
 24,000rpm
 1:1
 25 Nm
 about 5 kg

STANDARD DESIGN

- 1  Machine Connection
HSK - F63
- 2  Output spindle
Collet Chuck ER 32A

ADDITIONAL OPTIONS: MODULAR DESIGN

1



MACHINE CONNECTION



2



OUTPUT SPINDLE



i optional: Hydraulic expansion chuck with adapter

adapter size	∅ mm
	6 8 10 12 14 16 18 20

MACHINING



Drilling



Milling

SPECIFICATIONS

 Number of output spindles

 Axis angle

 Grease lubrication

TECHNICAL DRAWING

