

MORTISING UNIT – CLASSIC LINE

SMART NESTING

TECHNICAL DATA

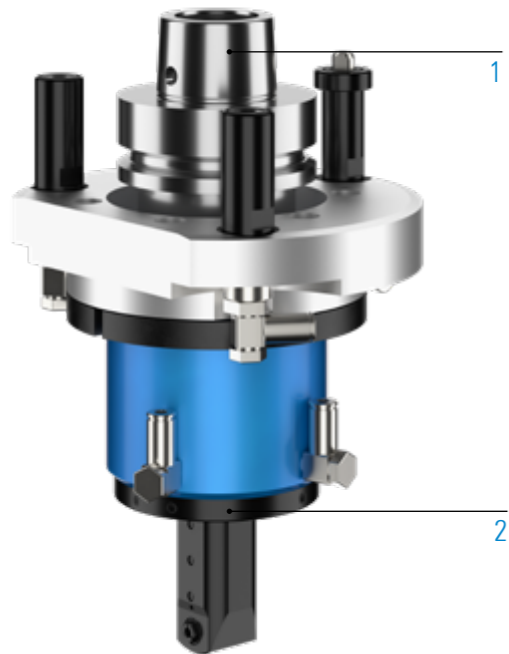

Lubrication
 Max. drive speed n_2
 Transmission ratio ($n_1: n_2$)
 Max. drive torque M_2
 Weight

Grease
 20,000rpm
 1:1
 2Nm
 about 3,5 kg

STANDARD DESIGN

- 1  Machine Connection
HSK - F63
- 2  Output spindle
Collet chuck
PFERD SPZ 947.01

ADDITIONAL OPTIONS: MODULAR DESIGN



MACHINE CONNECTION



OUTPUT SPINDLE



MACHINING



Drilling



Milling

SPECIFICATIONS



Number of output spindles



Axis angle



C-angle



Grease lubrication

TECHNICAL DRAWING

