

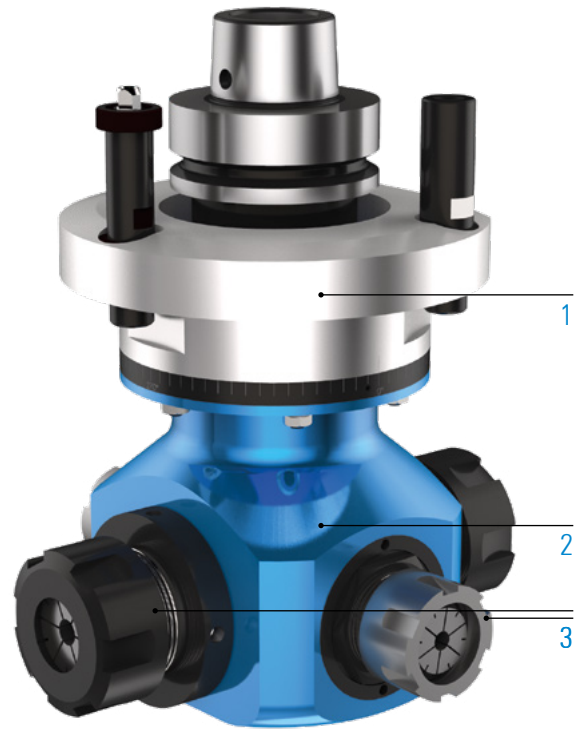



FOUR SIDED ANGLE HEAD – CLASSIC LINE QUATTRO

TECHNICAL DATA



Lubrication	Grease
Max. drive speed n_2	15,000rpm
Transmission ratio ($n_1: n_2$)	1:1.2
Max. drive torque M_2 milling spindle	25Nm
Max. drive torque M_2 drilling spindle	10Nm
Weight	about 6 kg

STANDARD DESIGN

- 1  Machine Connection
HSK - F63
- 2  Head length
M
- 3  Output spindle
Collet chuck ER32
+
 Collet chuck ER25M

ADDITIONAL OPTIONS: MODULAR DESIGN

1



MACHINE CONNECTION



2



HEAD LENGTH



3



OUTPUT SPINDLE

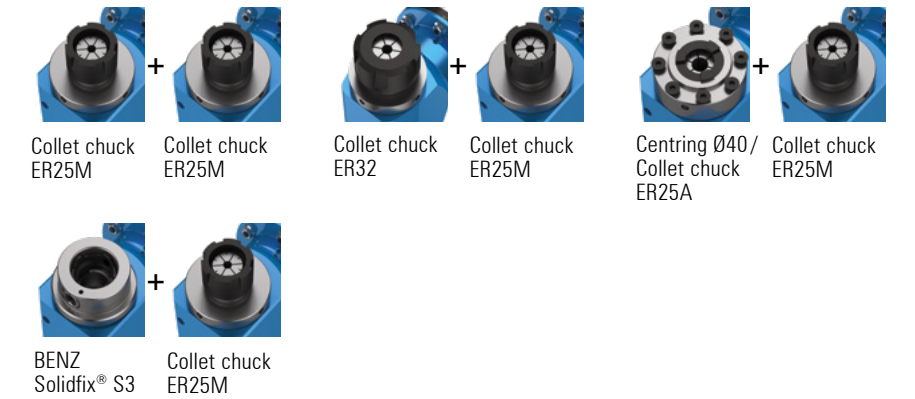

MACHINING

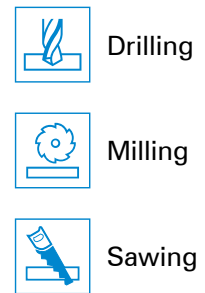

SPECIFICATIONS

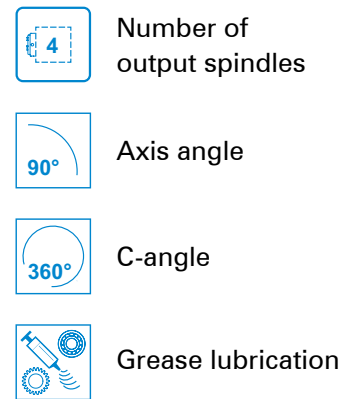

VIDEO

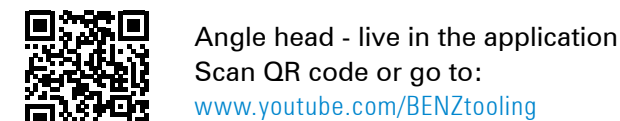

TECHNICAL DRAWING

