

MULTI-SPINDLE HEAD – CLASSIC LINE

MULTI V5

TECHNICAL DATA

Lubrication Grease
 Max. drive speed n_2 12,000 rpm
 Transmission ratio ($n_1: n_2$) 1:1
 Max. drive torque M_2 5Nm
 Weight about 5.5kg

STANDARD DESIGN

- 1  Machine Connection
HSK - F63
- 2  **5** Number of spindles
-  **32** Spindle distance
-  Output spindle
Weldon Ø10

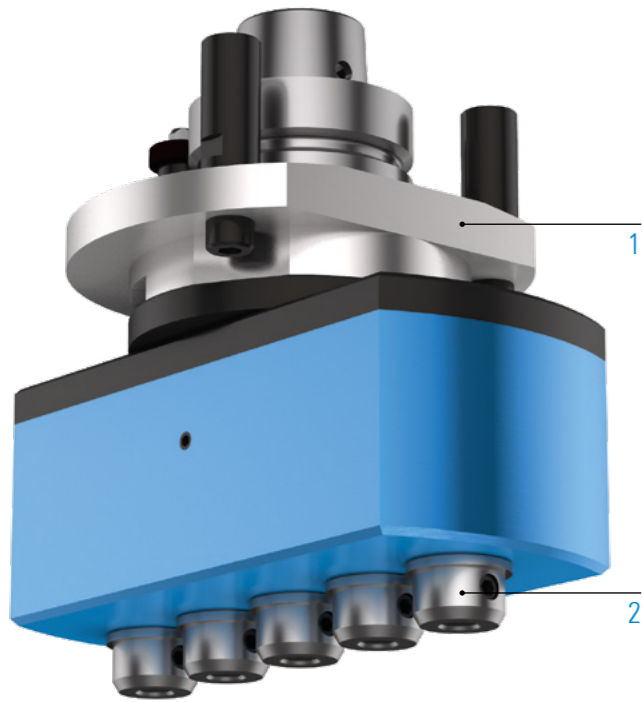

MACHINING







Drilling



Milling

SPECIFICATIONS

-  **5** Number of output spindles
-  **0°** Axis angle
-  **360°** C-angle
-  Grease lubrication

VIDEO



Multi-spindle head - live in the application
 Scan QR code or go to:
www.youtube.com/BENZtooling

TECHNICAL DRAWING



ADDITIONAL OPTIONS: MODULAR DESIGN



MACHINE CONNECTION



NUMBER OF SPINDLES



SPINDLE DISTANCE

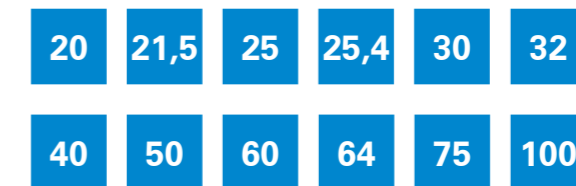

 Additional spindle distances/ numbers of spindles/ drilling patterns on request.

OUTPUT SPINDLE

