

MULTI-SPINDLE HEAD – CLASSIC LINE

MULTI H3+

TECHNICAL DATA

Lubrication Grease
 Max. drive speed n_2 10,000rpm
 Transmission ratio ($n_1: n_2$) 1:1.37
 Max. drive torque M_2 5Nm
 Weight about 4 kg

STANDARD DESIGN

- 1  Machine Connection
HSK - F63
- 2  **25** Spindle distance
-  Output spindle
Weldon Ø10

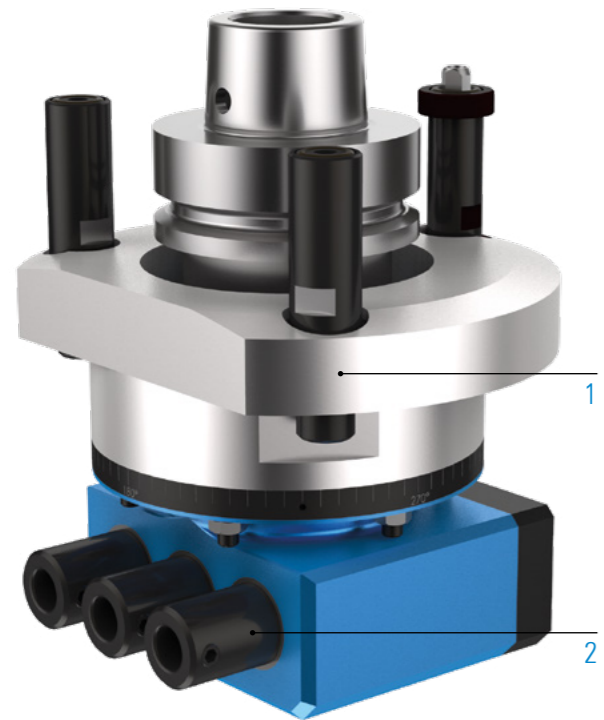

ADDITIONAL OPTIONS: MODULAR DESIGN



MACHINE CONNECTION

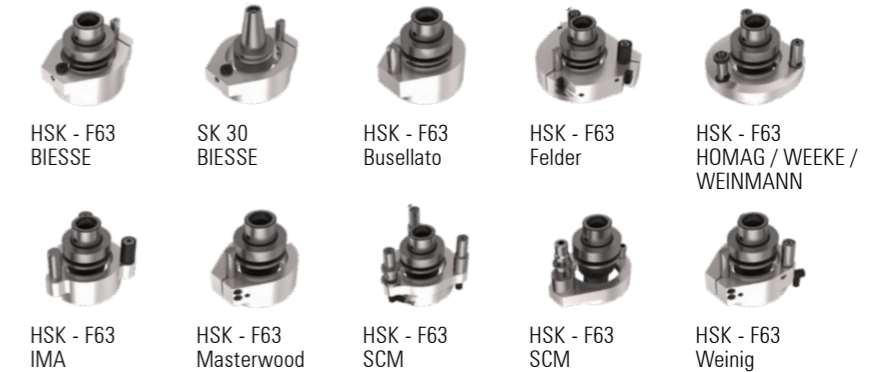

SPINDLE DISTANCE



i Additional spindle distances/ numbers of spindles/ drilling patterns on request

OUTPUT SPINDLE



MACHINING



Drilling



Milling

SPECIFICATIONS



Number of output spindle



Axis angle



C-angle



Grease lubrication

VIDEO



Multi-spindle head - live in the application
 Scan QR code or go to:
www.youtube.com/BENZtooling

TECHNICAL DRAWING

