

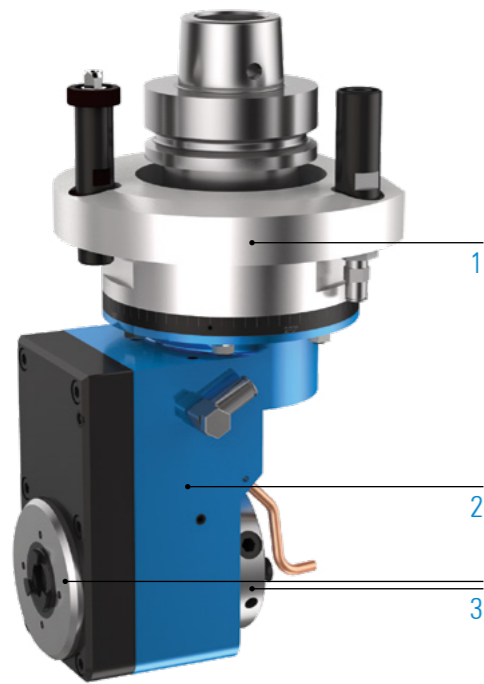



LOCK RECESS TRIMMING UNIT – CLASSIC LINE FORTE

TECHNICAL DATA

Lubrication	Grease
Max. drive speed n_2	15,000rpm
Transmission ratio ($n_1: n_2$)	1:1.2
Max. drive torque M_2	25Nm
Weight	about 5.5kg







STANDARD DESIGN

- 1  Machine Connection
HSK - F63
- 2  Head length
M
- 3  Output spindle
Centring Ø30/Whistle Notch Ø16/Ø20
+
 Collet chuck ER16A

MACHINING

-  Drilling
-  Milling
-  Sawing

SPECIFICATIONS

-  Number of output spindles
2
-  Axis angle
90°
-  C-angle
360°
-  Grease lubrication

VIDEO



Angle head - live in the application
Scan QR code or go to:
www.youtube.com/BENZtooling

TECHNICAL DRAWING



ADDITIONAL OPTIONS: MODULAR DESIGN

1



MACHINE CONNECTION



2



HEAD LENGTH



3



OUTPUT SPINDLE

