

FLOATING TRIMMING UNIT – CLASSIC LINE

FLOATING VC

TECHNICAL DATA

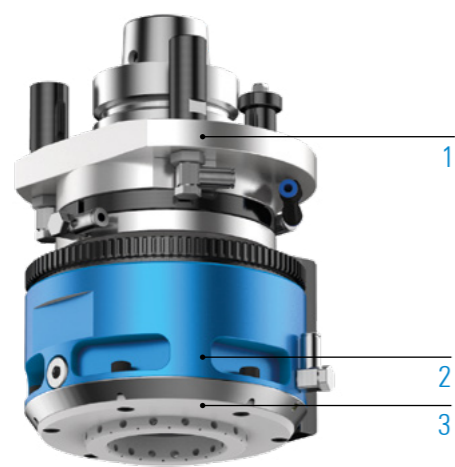

Lubrication Grease
 Max. drive speed n_2 24,000rpm
 Transmission ratio ($n_1: n_2$) 1:1
 Max. drive torque M_2 8Nm
 Weight about 4.5kg

STANDARD DESIGN

- 1  Machine connection
HSK - F63
- 2  Output spindle
Weldon $\varnothing 10/\varnothing 16$
- 3  50 Internal diameter of floating ring

ADDITIONAL OPTIONS: MODULAR DESIGN

1



MACHINE CONNECTION



 Weitere Informationen S. 106

2



OUTPUT SPINDLE

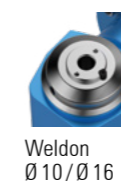

Weldon
 $\varnothing 10/\varnothing 16$

 Weitere Informationen S. 108

3



INTERNAL DIAMETER OF FLOATING RING

50

 Additional internal diameters of floating ring on request

MACHINING



Drilling



Milling

SPECIFICATIONS



1 Number of output spindles



0° Axis angle



360° C-angle



Grease lubrication

VIDEO



Unit - live in the application
 Scan QR code or go to:
www.youtube.com/BENZtooling

TECHNICAL DRAWING

