

HINGE MORTISING UNIT – CLASSIC LINE

CAVO V

TECHNICAL DATA

Lubrication Grease
 Max. drive speed n_2 4,000rpm
 Transmission ratio ($n_1: n_2$) 1:0.8
 Weight about 8 kg

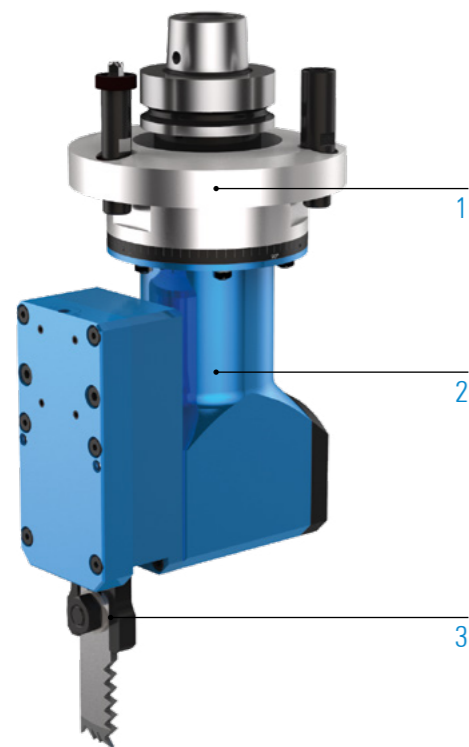

STANDARD DESIGN

- 1  Machine Connection
HSK - F63
- 2  Head length
- 3  Output spindle
Groove width 24

ADDITIONAL OPTIONS: MODULAR DESIGN

1



MACHINE CONNECTION



 Weitere Informationen S. 106

2

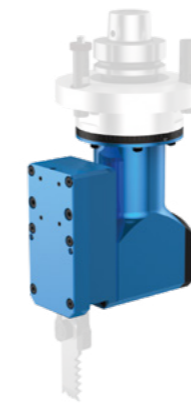

HEAD LENGTH



 Weitere Informationen S. 107

3



OUTPUT SPINDLE







MACHINING



Chiselling

SPECIFICATIONS

-  Number of output spindles
-  Axis angle
-  C-angle
-  Grease lubrication

VIDEO



Unit - live in the application
 Scan QR code or go to:
www.youtube.com/BENZtooling

TECHNICAL DRAWING

