

HINGE MORTISING UNIT – CLASSIC LINE

CAVO H

TECHNICAL DATA

Lubrication Grease
 Max. drive speed n_2 4,000rpm
 Transmission ratio (n_1 : n_2) 1:1
 Weight about 4.5kg

STANDARD DESIGN

- 1  Machine Connection
HSK - F63
- 2  Output spindle
Groove width 24

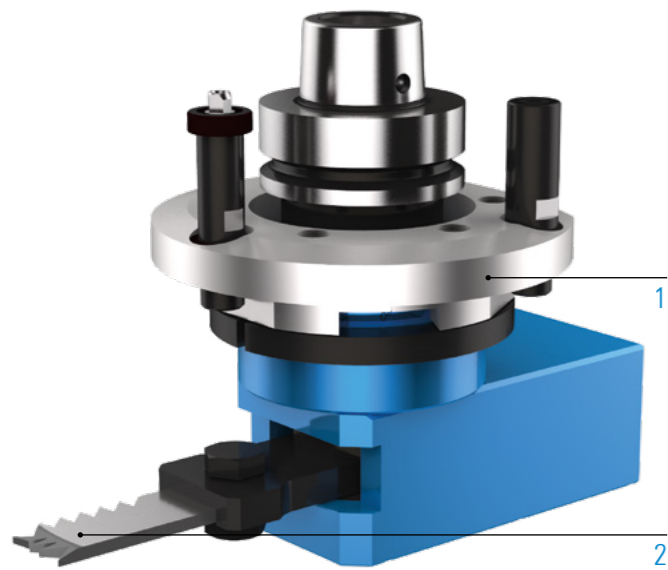

ADDITIONAL OPTIONS: MODULAR DESIGN



MACHINE CONNECTION



 Weitere Informationen S. 106

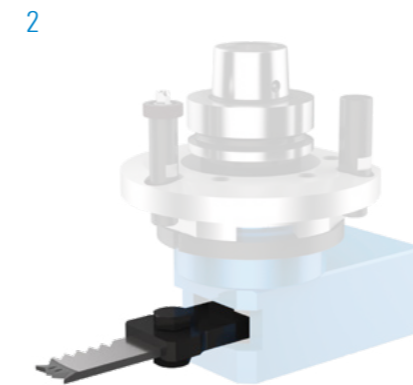

OUTPUT SPINDLE







Groove width 24

MACHINING



Chiselling

SPECIFICATIONS

-  Number of output spindles
-  Axis angle
-  C-angle
-  Grease lubrication

VIDEO



Unit - live in the application
 Scan QR code or go to:
www.youtube.com/BENZtooling

TECHNICAL DRAWING

