

MORTISING CHAIN UNIT – CLASSIC LINE

CATENO F

TECHNICAL DATA

Lubrication	Grease
Max. drive speed n_2	5,000rpm
Transmission ratio ($n_1: n_2$)	1:1
Max. drive torque M_2	20 Nm
Weight	about 10,5 kg

STANDARD DESIGN

- 1  Machine Connection
HSK - F63
- 2  Mortising chain set
Slot depth 300 mm
Slot length 50 mm
slot width 6 mm - 21 mm

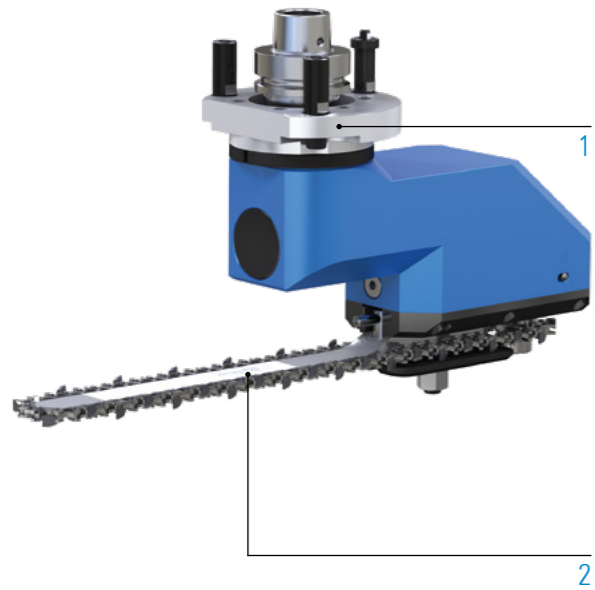

ADDITIONAL OPTIONS: MODULAR DESIGN

1

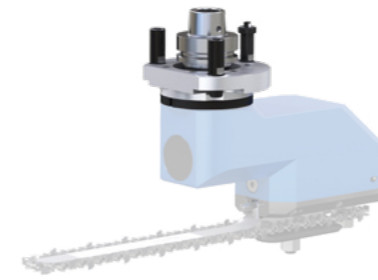

MACHINE CONNECTION



2

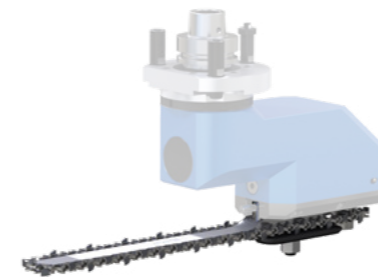





MORTISING CHAIN SET



MACHINING



SPECIFICATIONS

-  Number of output spindles
-  Axis angle
-  C-angle
-  Grease lubrication

VIDEO

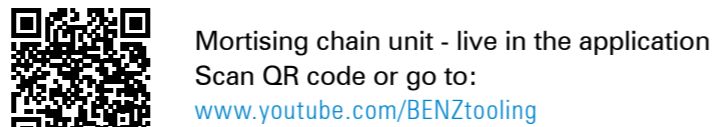

TECHNICAL DRAWING

