

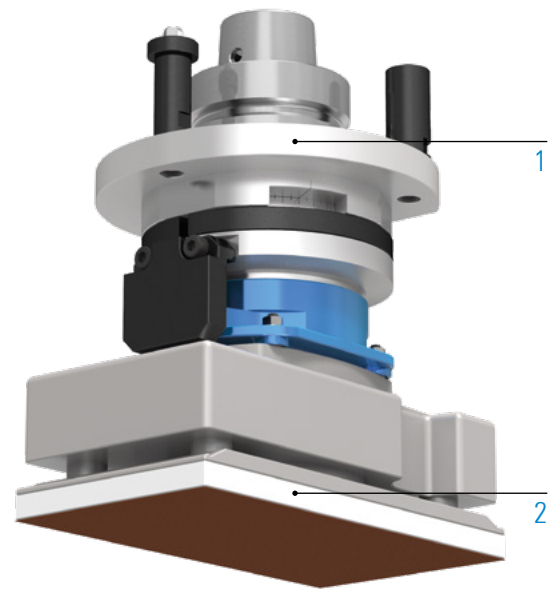

SCHWINGSCHLEIFAGGREGAT – CLASSIC LINE ZUCCO

TECHNISCHE DATEN

Schmierung	Fett
max. Abtriebsdrehzahl n_2	3.000 min ⁻¹
Übersetzung ($n_1: n_2$)	1:1
Gewicht	ca. 3 kg



STANDARDAUSFÜHRUNG

-  Maschinenanbindung
HSK - F63
-  Schleifschuh
Breite 93 mm, Länge 175 mm

WEITERE OPTIONEN: MODULARER AUFBAU

1

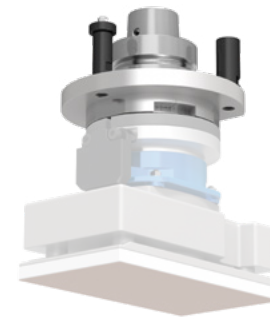

MASCHINENANBINDUNG



 Weitere Informationen S. 106

2

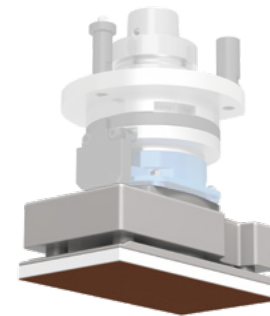

SCHLEIFSCHUH



Breite 93 mm,
Länge 175 mm

BEARBEITUNG



Schleifen

SPEZIFIKATIONEN

Anzahl
Werkzeugaufnahmen

Achswinkel



C-Winkel



Fettschmierung

DIREKT BESTELLEN



Anfrageformular:
www.benztooling.com/de/produkte