

MEHRSPINDELKOPF – CLASSIC LINE MULTI V5

TECHNISCHE DATEN

Schmierung **Fett**
 max. Abtriebsdrehzahl n_2 **12.000 min⁻¹**
 Übersetzung ($n_1 : n_2$) **1:1**
 max. Abtriebsdrehmoment M_2 **5 Nm**
 Gewicht **ca. 5,5 kg**

STANDARD AUSFÜHRUNG

- 1  Maschinenanbindung
HSK - F63
- 2  **5** Spindelanzahl
-  **32** Spindelabstand
-  Werkzeugaufnahme
Weldon Ø10

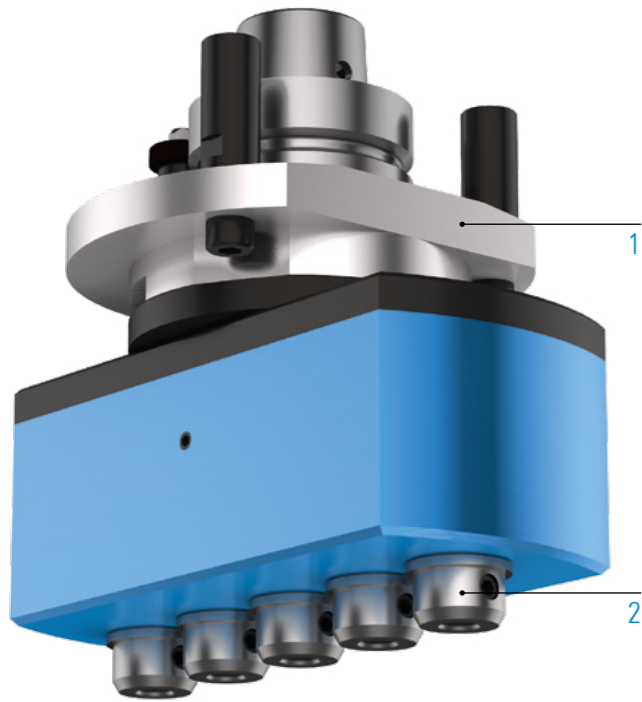

BEARBEITUNG



Bohren



Fräsen

SPEZIFIKATIONEN

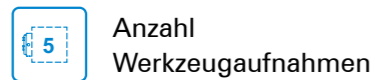

Anzahl
Werkzeugaufnahmen

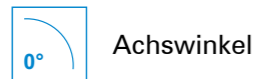

Achswinkel



C-Winkel



Fettschmierung

VIDEO



Mehrspindelkopf – live in der Anwendung
 QR Code scannen oder alternativ:
www.youtube.com/BENZtooling

TECHNISCHE ZEICHNUNG



WEITERE OPTIONEN: MODULARER AUFBAU

1



2



MASCHINENANBINDUNG



SPINDEL ANZAHL



SPINDEL ABSTAND

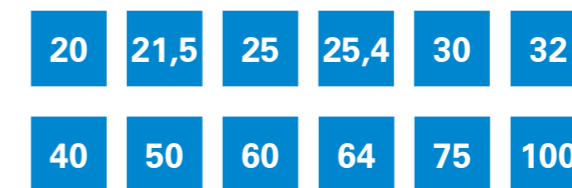

 Weitere Spindelabstände/-anzahlen/Bohrbilder auf Anfrage

WERKZEUGAUFNAHME

