

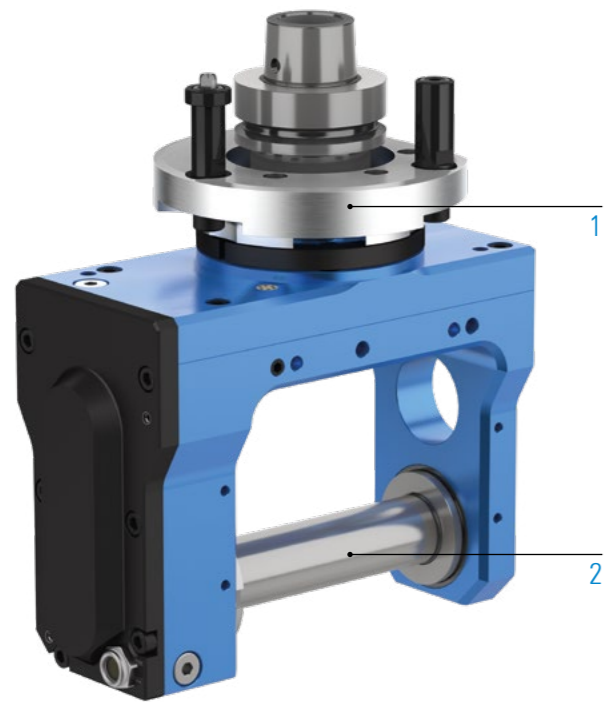

HOBELWELLENAGGREGAT – PREMIUM LINE MOULDER

TECHNISCHE DATEN



Schmierung	Ölbad
max. Abtriebsdrehzahl n_2	10.000 min ⁻¹
Übersetzung ($n_1: n_2$)	1:0,7
max. Abtriebsdrehmoment M_2	25 Nm
Gewicht	ca. 10 kg
max. Werkzeugdurchmesser	Ø 180

STANDARDAUSFÜHRUNG

- 1  Maschinenanbindung
HSK - F63
- 2  Werkzeugaufnahme
Dorn Ø30, WZ-Länge 120 mm

WEITERE OPTIONEN: MODULARER AUFBAU

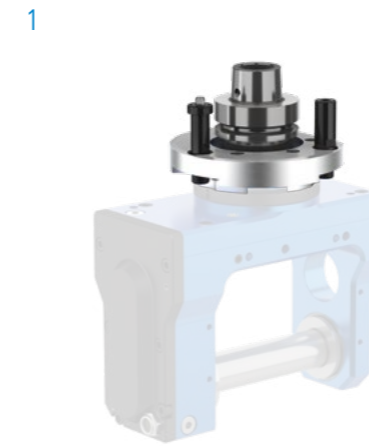



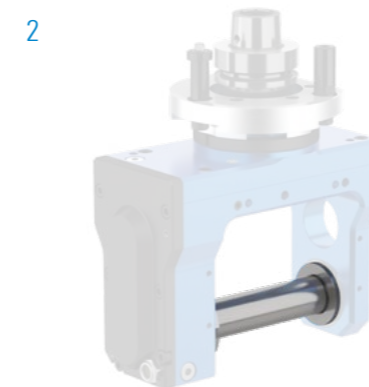

MASCHINENANBINDUNG

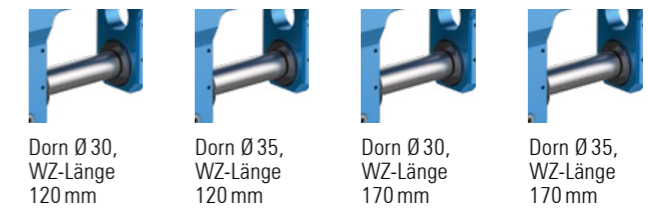



WERKZEUGAUFNAHME



BEARBEITUNG

-  Fräsen
-  Sägen
-  Hobeln
-  Bürsten

SPEZIFIKATIONEN

-  Anzahl
Werkzeugaufnahmen
-  Achswinkel
-  C-Winkel
-  Ölbadschmierung

VIDEO



Aggregat – live in der Anwendung
QR Code scannen oder alternativ:
www.youtube.com/BENZtooling

TECHNISCHE ZEICHNUNG

