

TASTAGGREGAT – CLASSIC LINE

FLOATING V C

TECHNISCHE DATEN

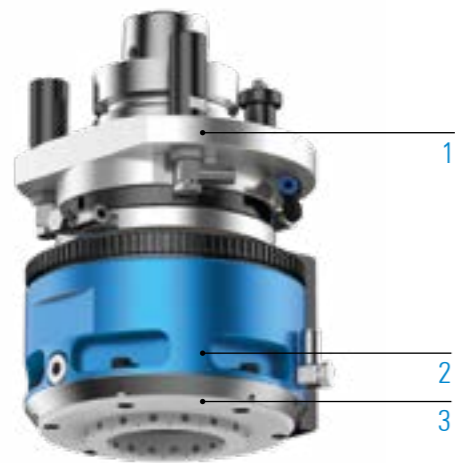

Schmierung **Fett**
 max. Abtriebsdrehzahl n_2 **24.000 min⁻¹**
 Übersetzung ($n_1: n_2$) **1:1**
 max. Abtriebsdrehmoment M_2 **8Nm**
 Gewicht **ca. 4,5kg**

STANDARD AUSFÜHRUNG

- 1  Maschinenanbindung
HSK - F63
- 2  Werkzeugaufnahme
Weldon $\varnothing 10/\varnothing 16$
- 3  **50** Tastringinnendurchmesser

BEARBEITUNG



Bohren



Fräsen

SPEZIFIKATIONEN



Anzahl
Werkzeugaufnahmen



Achswinkel



C-Winkel



Fettschmierung

VIDEO



Aggregat – live in der Anwendung
 QR Code scannen oder alternativ:
www.youtube.com/BENZtooling

TECHNISCHE ZEICHNUNG



WEITERE OPTIONEN: MODULARER AUFBAU

1



MASCHINENANBINDUNG



2



WERKZEUGAUFNAHME



Weldon
 $\varnothing 10/\varnothing 16$

3



TASTRINGINNENDURCHMESSER

50

 Weitere Tastringinnendurchmesser auf Anfrage