

TASTAGGREGAT – CLASSIC LINE FLOATING HB

TECHNISCHE DATEN

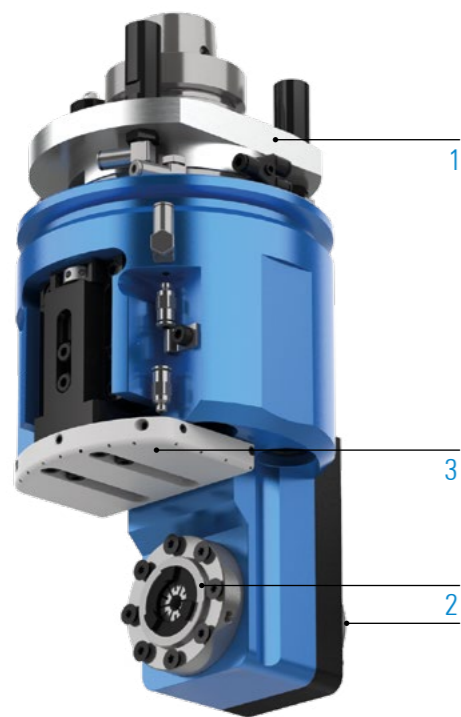

Schmierung **Fett**
 max. Abtriebsdrehzahl n_2 **15.000 min⁻¹**
 Übersetzung ($n_1: n_2$) **1:1,2**
 max. Abtriebsdrehmoment M_2 **25 Nm**
 Gewicht **ca. 9,9 kg**

STANDARDAUSFÜHRUNG

- 1  **Maschinenanbindung
HSK - F63**
- 2  **Werkzeugaufnahme
Zentrier-Ø40/ Spannzange ER25A**
-  **Spannzange ER16A**
- 3  **Material Tastelement
Kunststoff**

WEITERE OPTIONEN: MODULARER AUFBAU



MASCHINENANBINDUNG

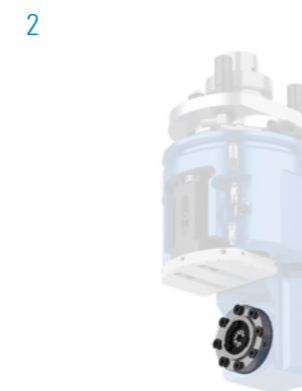

WERKZEUGAUFNAHME

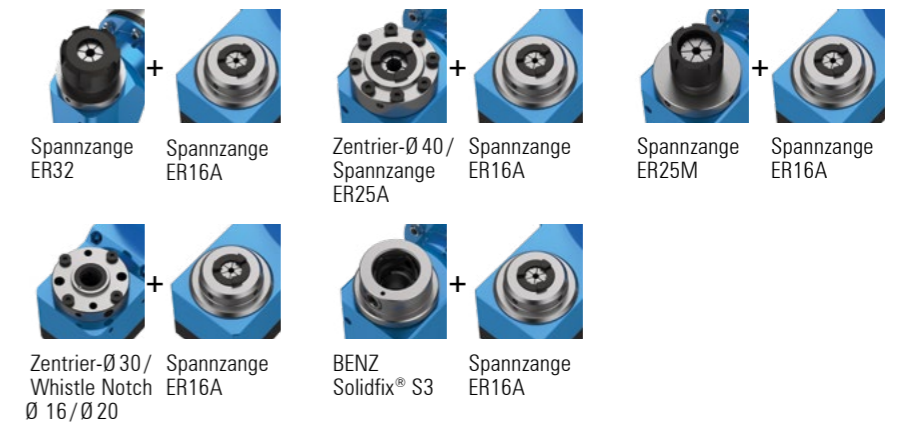

MATERIAL TASTELEMENT



BEARBEITUNG



Bohren



Fräsen

SPEZIFIKATIONEN



Anzahl
Werkzeugaufnahmen



Achswinkel



C-Winkel



Fettschmierung

TECHNISCHE ZEICHNUNG

