

# SCHWENKKOPF – PREMIUM LINE

## FLEX D (MANUELL VERSTELLBAR)

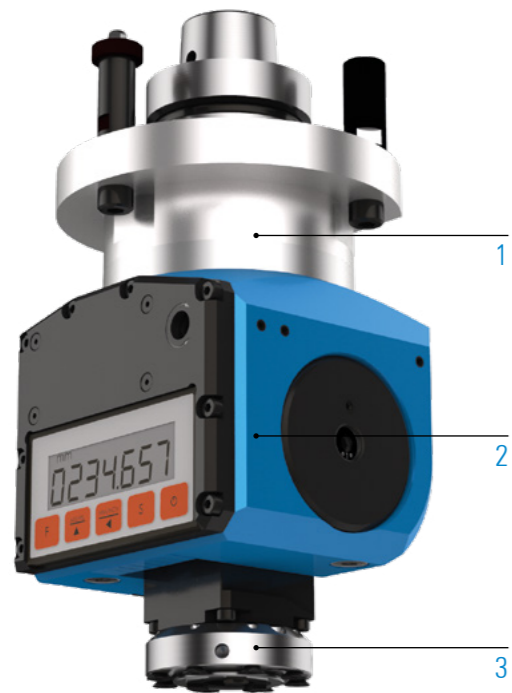

### TECHNISCHE DATEN

Schmierung	Ölbad
max. Abtriebsdrehzahl $n_2$	15.000 min <sup>-1</sup>
Übersetzung ( $n_1: n_2$ )	1:0,94
max. Abtriebsdrehmoment $M_2$	26,5 Nm
Gewicht	ca. 9 kg

- mit digitaler Winkelanzeige
- mit manueller Winkeleinstellung

### STANDARD AUSFÜHRUNG

-  Maschinenanbindung  
HSK - F63
-  Vorsatzkopflänge
-  Werkzeugaufnahme  
Zentrier-Ø40/Spannzange ER25A

### WEITERE OPTIONEN: MODULARER AUFBAU

1



#### MASCHINENANBINDUNG



2



#### VORSATZKOPFLÄNGE



3



#### WERKZEUGAUFNAHME



### BEARBEITUNG



Bohren



Fräsen



Sägen

### SPEZIFIKATIONEN

Anzahl  
Werkzeugaufnahmen

Achswinkel



C-Winkel



Ölbad Schmierung

### VIDEO



Winkelkopf – live in der Anwendung  
QR Code scannen oder alternativ:  
[www.youtube.com/BENZtooling](http://www.youtube.com/BENZtooling)

### TECHNISCHE ZEICHNUNG

