

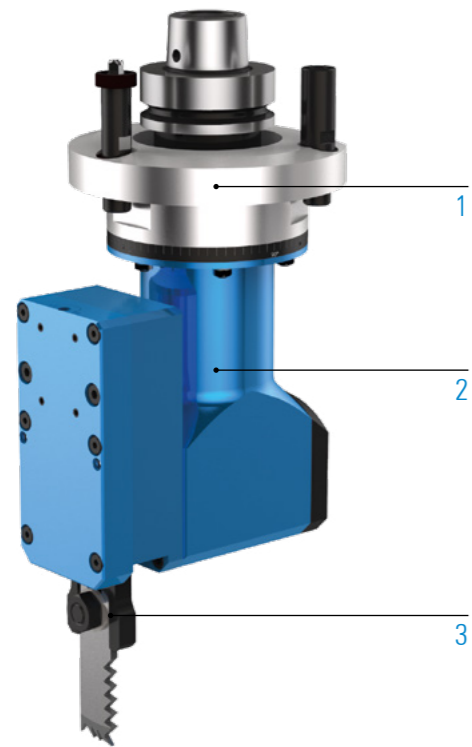

FITSCHENAGGREGAT – CLASSIC LINE CAVO V

TECHNISCHE DATEN

Schmierung Fett
 max. Abtriebsdrehzahl n_2 4.000 min⁻¹
 Übersetzung (n_1 : n_2) 1:0,8
 Gewicht ca. 8 kg



STANDARD AUSFÜHRUNG

- 1  Maschinenanbindung
HSK - F63
- 2  Vorsatzkopflänge
- 3  Werkzeugaufnahme
Nutbreite 24

BEARBEITUNG



Stemmen

SPEZIFIKATIONEN

-  Anzahl
Werkzeugaufnahmen
-  Achswinkel
-  C-Winkel
-  Fettschmierung

VIDEO



Fitschenaggregat – live in der Anwendung
 QR Code scannen oder alternativ:
www.youtube.com/BENZtooling

TECHNISCHE ZEICHNUNG



WEITERE OPTIONEN: MODULARER AUFBAU

1



MASCHINENANBINDUNG



 Weitere Informationen S. 106

2

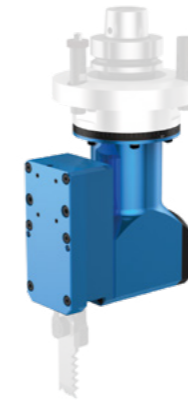

VORSATZKOPFLÄNGE



 Weitere Informationen S. 107

3



WERKZEUGAUFNAHME



Nutbreite 24