

ECKENAUSKLINKAGGREGAT – CLASSIC LINE

ANGULO

TECHNISCHE DATEN

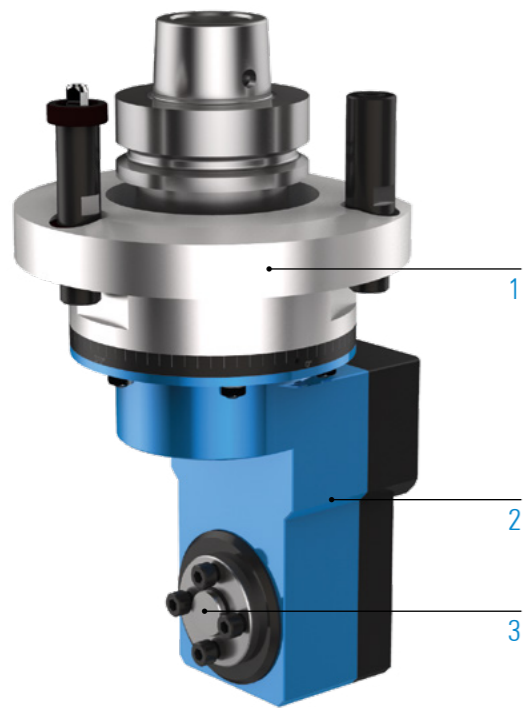

Schmierung
 max. Abtriebsdrehzahl n_2
 Übersetzung ($n_1: n_2$)
 max. Abtriebsdrehmoment M_2
 Gewicht

Fett
 10.000 min^{-1}
 1:1,3
 20 Nm
 ca. 4,5 kg

STANDARDAUSFÜHRUNG

- 1  Maschinenanbindung
HSK - F63
- 2  Vorsatzkopflänge
- 3  Werkzeugaufnahme
Zentrier-Ø 16

BEARBEITUNG



Bohren



Fräsen

SPEZIFIKATIONEN



Anzahl
Werkzeugaufnahmen



Achswinkel



C-Winkel



Fettschmierung

VIDEO



Winkelkopf – live in der Anwendung
 QR Code scannen oder alternativ:
www.youtube.com/BENZtooling

TECHNISCHE ZEICHNUNG



WEITERE OPTIONEN: MODULARER AUFBAU

1



MASCHINENANBINDUNG



HSK - F63
BIESSE



SK 30
BIESSE



HSK - F63
Busellato



HSK - F63
Felder



HSK - F63
HOMAG / WEEKE /
WEINMANN



HSK - F63
IMA



HSK - F63
Masterwood



HSK - F63
SCM



HSK - F63
SCM



HSK - F63
Weinig

2



VORSATZKOPFLÄNGE



3



WERKZEUGAUFNAHME



Spannzange
ER16A



Spannzange
ER25M



Zentrier-Ø 16