

# BROACHING UNITS FOR MACHINING CENTERS

## BENZ LINS - AXIAL

### ▶ PRODUCT IN OVERVIEW

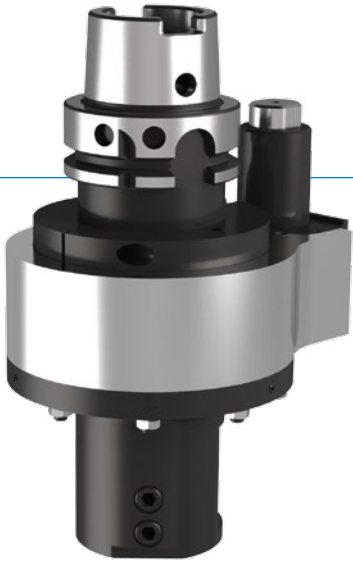

### ▶ TYPE

**WAS**

### ▶ DRIVE CONE



SK  
DIN 69871



MAS BT



CAT



HSK  
DIN 69893



Coromant  
Capto®



KM™

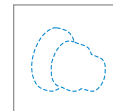

Other

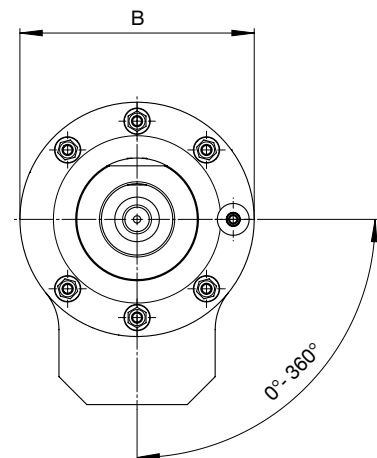
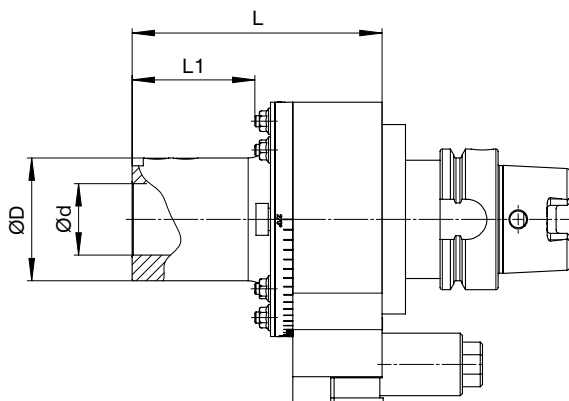

WAS	
Usable working stroke / Total stroke	= depending on Tool
Material strength <sub>max</sub>	= 1,100 N/mm <sup>2</sup>

▶ Technical data						
L1 [mm]	Ød [mm]	ØD [mm]	B [mm]	L [mm]	Weight [kg]	

55	16-32	55	105	112	approx. 5	
----	-------	----	-----	-----	-----------	--