

LIVE TOOLS – BMT 68

RADIAL, BROACHING UNIT - BENZ LINA 4.0

TECHNICAL DATA



LENGTH L1

80

OUTPUT SPINDLES



similar to prism
Ø 30mm



Performance data

PD	IC p _{max} [bar]	n _{1 max} / *n _{2 max} [min ⁻¹]	M _{1 max} / F _{c max} [Nm / N]
1	50	3000 / 1500	15 / 1700
2	50	2000 / 1000	23 / 1700

*number of double stroke per minute

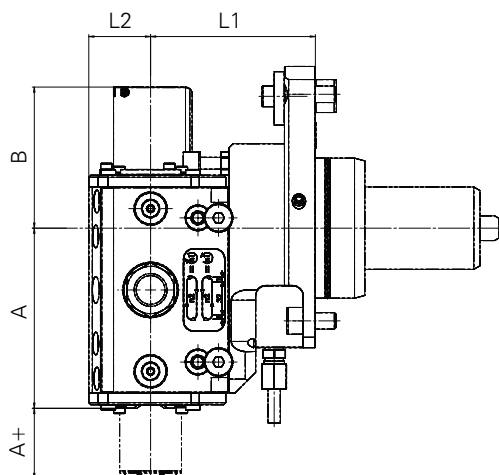

Typ	Technical data										Order No.
	Size Stößel	i	EC 	IC 	**Hub [mm]	A [mm]	B [mm]	L2 [mm]	L1 [mm]	LD	
GS	30	2:1	✓	✓	32	34	68,5	30	80	1	114GS12902B2R-80
GSL	30	2:1	✓	✓	51	116,5	87,5	30	80	2	114GSL12908B2R-80

*number of double stroke per minute

**usable working stroke