

LIVE TOOLS – BMT 68

ADJUSTABLE

TECHNICAL DATA



OUTPUT SPINDLES



Collet chuck
System ER
DIN 6499

i Other output spindles
available upon request



PD	Performance data		
	IC p _{max} [bar]	n _{1 max} / n _{2 max} [min ⁻¹]	M _{1 max} / M _{2 max} [Nm]
1	-	6000 / 4900	32 / 39
2	50	6000 / 4900	32 / 39

Collet Chuck

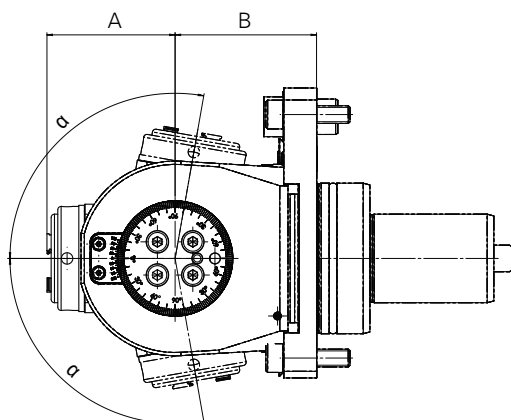

Output spindle	Technical data							Order No.
	Size Spindle	i	EC 	IC 	A _{max} [mm]	B [mm]	PD	
Collet Chuck	ER25	1:0,816	✓	-	57,9	62	1	114FDX12949E5A
	ER25	1:0,816	✓	✓	62,9	62	2	114GDX12949E5A