

ANGETRIEBENES WERKZEUG – BMT 68

RADIAL, ZURÜCKGESETZT

TECHNISCHE DATEN



LÄNGE L1

80

WERKZEUGAUFNAHMEN



BENZ
Solidfix®



Collet chuck
System ER
DIN 6499



Weitere Werkzeugaufnahmen auf Anfrage



Leistungs Daten

LD	IK p _{max} [bar]	n _{1 max} / n _{2 max} [min ⁻¹]	M _{1 max} / M _{2 max} [Nm]
1	-	6000 / 6000	70 / 70
2	100	6000 / 6000	70 / 70

BENZ Solidfix® / Spannzange

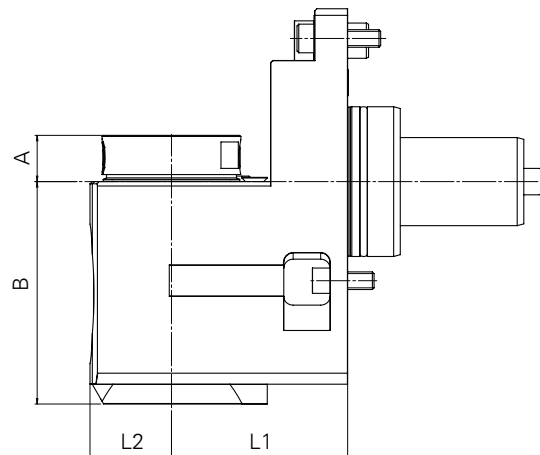

Technische Daten

Werkzeugaufnahme	Größe Spindel	i	EK	IK	A _{max} [mm]	B [mm]	L2 [mm]	L1 [mm]	LD	Bestellnummer
BENZ Solidfix®	S4	1:1	✓	-	21	101	37	80	1	114FBX12949S4L-80
	S4	1:1	✓	✓	21	111	37	80	2	114GBX12949S4L-80
Spannzange	ER32	1:1	✓	-	18,1	101	37	80	1	114FBX12949E6AL-80
	ER32	1:1	✓	✓	23,2	111	37	80	2	114GBX12949E6AL-80