

HAAS VDI TOOLING

Haas CNC turning centers with VDI 40 turret

Promo

Metal machining

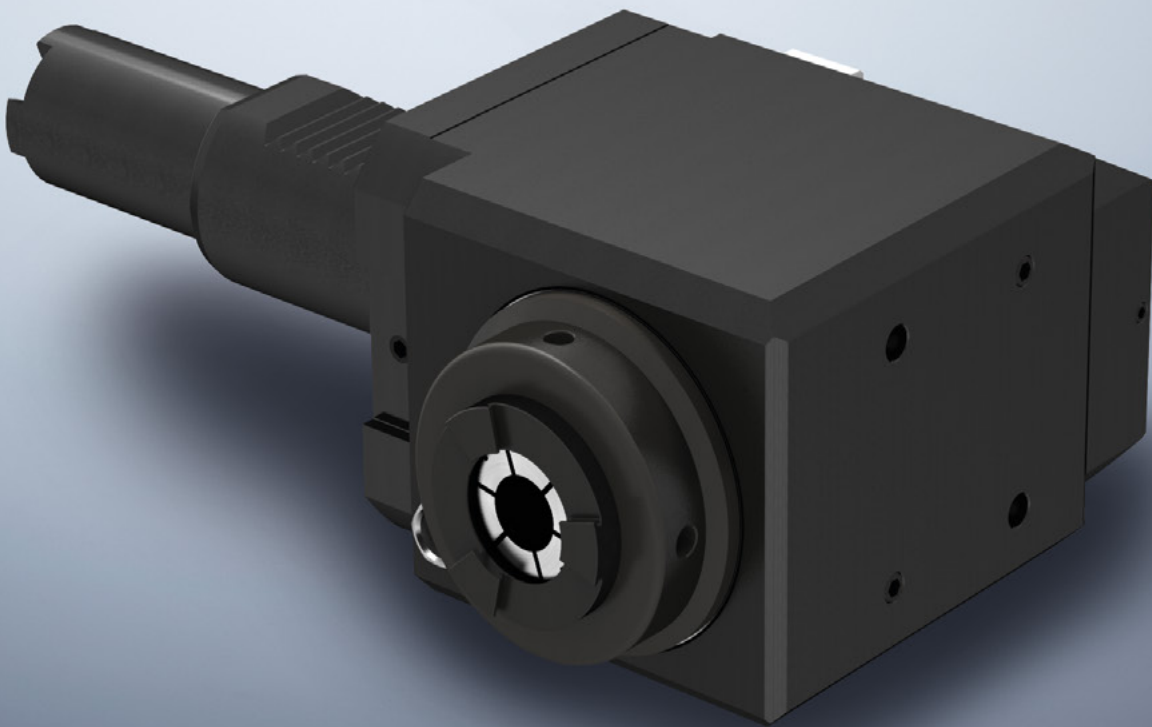

OEM SUPPLIER

HAAS LIVE TOOLS VDI 40 + ADAPTER

BENZ SOLIDFIX® - COLLET CHUCK

BUNDLES

SET	Description	BENZ Order No.
Bundle I	BENZ Solidfix®: 1 x axial live tool (ext. coolant) 1 x ER32 collet chuck adapter 1 x allen key	114SET1040001
Bundle II	BENZ Solidfix®: 1 x radial live tool (ext. coolant) 1 x ER 32 collet chuck adapter 1 x allen key	114SET1040002
Bundle III	Collet chuck: 2 x axial live tools (ext. coolant) 2 x radial live tools (ext. coolant) 1 x set of wrenches	114SET1040003
Bundle IV	BENZ Solidfix®: 2 x axial live tools (ext. coolant) 2 x radial live tools (ext. coolant) 4 x ER 32 collet chuck adapter 1 x allen key	114SET1040005

HAAS OEM TOOLS

SET	Description	HAAS Order No.	BENZ Order No.
Axial / straight	Collet chuck: 1 x axial live tool (ext. coolant) 1 x set of wrenches	HLT-AHTH	114DA10441E6A-Z
Radial / 90°	Collet chuck: 1 x radial live tool (ext. coolant) 1 x set of wrenches	HLT-RHTH	114FAX10449E6AL-Z

HAAS LATHES

ST-10 | ST-10Y | ST-15 | ST-15Y | ST-20 | ST-20Y | ST-20SS | ST-20SSY | ST-25 | ST-25Y | ST-30 | ST-30Y | ST-30SS | ST-30SSY | ST-35 | ST-35Y | ST-40 | ST-40L | SL-20 | SL-30 | DS-30 | DS-30Y | DS-30SS | DS-30SSY

AXIAL

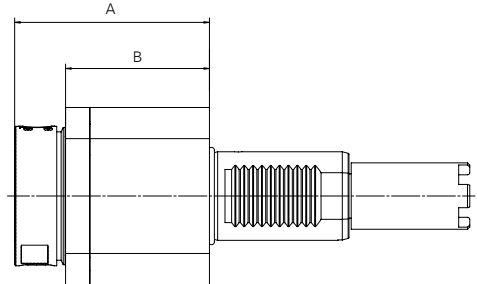

		Technical data								
Output spindle	Size Spindle	i	EC	IC*	$n_{1\max} / n_{2\max}$ [min ⁻¹]	$M_{1\max} / M_{2\max}$ [Nm]	A_{\max} [mm]	B [mm]	Order No.	
BENZ Solidfix®	S4	1:1	✓	-	6.000 / 6.000	70 / 70	88	65	114DA10441S4	
Collet chuck	ER32	1:1	✓	-	6.000 / 6.000	70 / 70	76,1	65	114DA10441E6A	

RADIAL

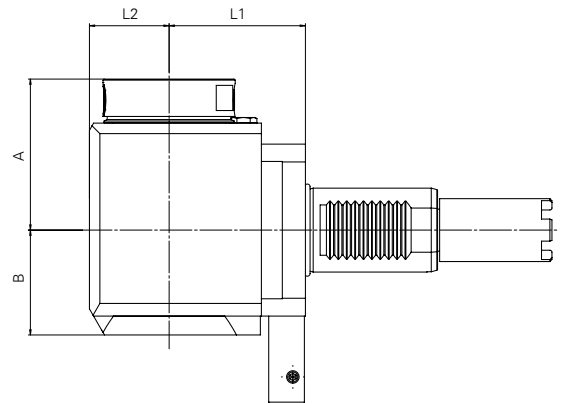

		Technical data									
Output spindle	Size Spindle	i	EC	IC*	$n_{1\max} / n_{2\max}$ [min ⁻¹]	$M_{1\max} / M_{2\max}$ [Nm]	A_{\max} [mm]	B [mm]	L1 [mm]	L2 [mm]	Order No.
BENZ Solidfix®	S4	1:1	✓	-	6.000 / 6.000	70 / 70	72	50	65	38	114FAX10449S4L
Collet chuck	ER32	1:1	✓	-	6.000 / 6.000	70 / 70	69,1	50	65	38	114FAX10449E6AL

BENZ SOLIDFIX® - ADAPTER

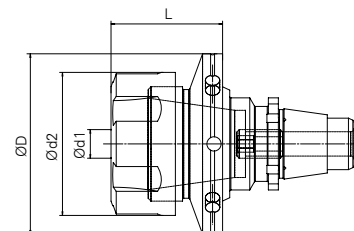

		Technical data					
Adapter	Size	Type	ØD [mm]	Ød1 [mm]	Ød2 [mm]	L [mm]	Order No.
Collet chuck - internal clamping nut	S4	ER32 8° ER	63	2-20	50	39	694.130E639

collet not included in delivery

BENZ GmbH Werkzeugsysteme

Im Mühlegrün 12
D-77716 Haslach
T +49 7832 704-0
F +49 7832 704-8001
info@benztooling.com
www.benztooling.com

