

DMG MORI BMT 60

Live Tools & Static Holders

Tooling & Machine Tooling Technology

Metal machining

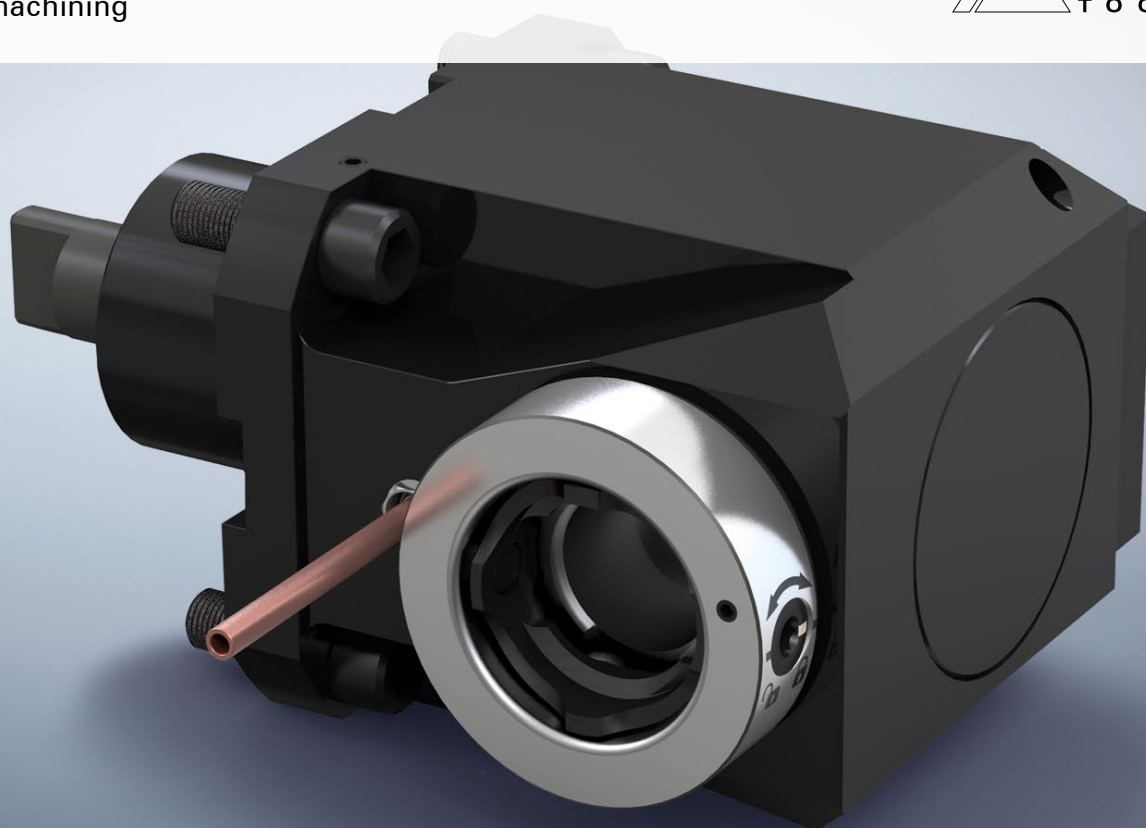



AT BENZ GMBH WERKZEUGSYSTEME, OUR MAXIM, INNOVATION, PRECISION, PASSION, IS FAR MORE THAN JUST A MARKETING FORMULA. RATHER, IT DESCRIBES THE CORE GOALS OF OUR BUSINESS WHILE ALSO OUTLINING THE REASONS WHY WE HAVE BEEN ABLE TO COMPETE IN THE MARKET SUCCESSFULLY WITH TOOL SYSTEMS FOR WOODWORKING, METAL MACHINING AND COMPOSITE MATERIAL PROCESSING FOR MORE THAN 40 YEARS.

INNOVATIONS ARE IMPORTANT TO US. BUT WE ALSO RECOGNIZE THAT THEY CAN BE SUCCESSFUL ONLY IF THEY PRECISELY MEET THE NEEDS OF OUR CUSTOMERS. THIS IS WHY WE HAVE MAINTAINED A STRICT FOCUS ON OUR CUSTOMERS FOR MANY YEARS. WE ENSURE THAT OUR DEVELOPMENTS AND INNOVATIONS SIMPLIFY YOUR PRODUCTION PROCESSES AND LOWER YOUR MANUFACTURING COSTS - AND ULTIMATELY IMPROVE YOUR COMPETITIVENESS AS A RESULT.



BENZ GMBH

WERKZEUGSYSTEME

FOR DMG MORI BMT MACHINES
EXCERPT PRODUCT RANGE



More information about our BENZ products and accessories can be found at the download area of our website.

<https://www.benztooling.com/en/services/downloads>



BMT 60

Live Tools | Static Holders



LIVE TOOLS



AXIAL

6



RADIAL

7



RADIAL, DOUBLE

8



ADJUSTABLE

9



BROACHING UNIT
BENZ LinA 4.0

10

STATIC HOLDERS



STANDARD

12

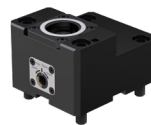

BENZ CAPTO™

13

LIVE TOOL – BMT 60

AXIAL

TECHNICAL DATA



OUTPUT SPINDLES



BENZ
Solidfix®



Collet chuck
System ER
DIN 6499

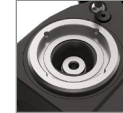

BENZ
CAPTO™

i Other output spindles available upon request

BENZ Solidfix® / Collet chuck

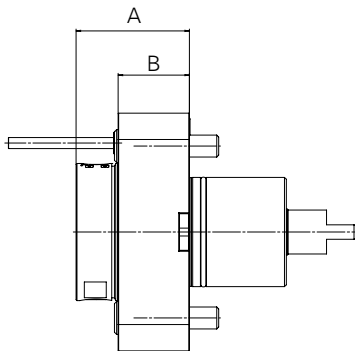

BENZ CAPTO™

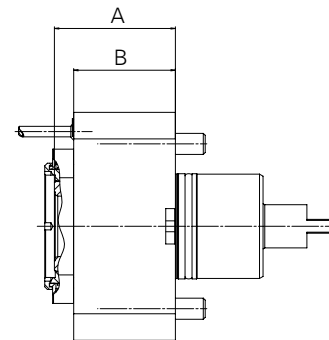

Output spindle	Technical Data								Order No.
	Size Spindle	i	EC	IC*	$n_{1\max} / n_{2\max}$ [rpm]	$M_{1\max} / M_{2\max}$ [Nm]	A_{\max} [mm]	B [mm]	
BENZ Solidfix®	S5	1:1	✓		6000 / 6000	100 / 100	62	39	115DA03500S5
	S5	1:1	✓	✓	6000 / 6000	100 / 100	62	39	115EA03500S5
Collet chuck	ER40A	1:1	✓		6000 / 6000	100 / 100	80	55	115DA03551E7A
	ER40A	1:1	✓	✓	4500 / 4500	100 / 100	84,9	55	115EA03551E7A
BENZ CAPTO™	C5	1:1	✓		6000 / 6000	100 / 100	74,5	58	115DA03500L5B
	C5	1:1	✓	✓	6000 / 6000	100 / 100	89,5	72,5	115EA03500L5B

*Internal Cooling $p_{\max} = 50$ bar

LIVE TOOL – BMT 60 RADIAL

TECHNICAL DATA



LENGTH L1

90

OUTPUT SPINDLES



BENZ
Solidfix®

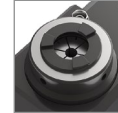

Collet chuck
System ER
DIN 6499



BENZ
CAPTO™



Other output spindles
available upon request



BENZ Solidfix® / Collet chuck

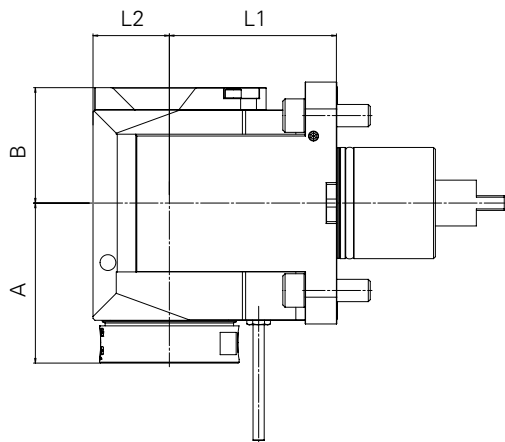

BENZ CAPTO™

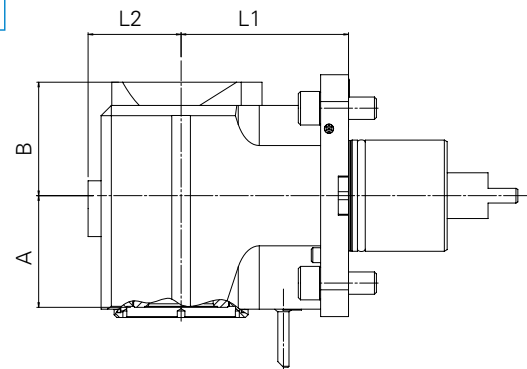

Output spindle	Size Spindle	i	EC	IC*	$n_{1\max} / n_{2\max}$ [rpm]	$M_{1\max} / M_{2\max}$ [Nm]	A_{\max} [mm]	B [mm]	L1 [mm]	L2 [mm]	Order No.
BENZ Solidfix®	S5	1:1	✓	-	6000 / 6000	150 / 150	86	62	90	41	115FAX03559S5D
	S5	1:1	✓	✓	6000 / 6000	150 / 150	86	68	90	41	115GAX03559S5D
Collet Chuck	ER40A	1:1	✓	-	6000 / 6000	150 / 150	81,5	62	90	41	115FAX03559E7AD
	ER40A	1:1	✓	✓	6000 / 6000	150 / 150	86,4	68	90	41	115GAX03559E7AD
BENZ CAPTO™	C5	1:1	✓	-	6000 / 6000	150 / 150	65,5	61	90	50	115FAX03559L5BD
	C5	1:1	✓	✓	6000 / 6000	150 / 150	65,5	67,5	90	50	115GAX03559L5BD

*Internal Cooling $p_{\max} = 100$ bar

LIVE TOOL – BMT 60

RADIAL, DOUBLE

TECHNICAL DATA



LENGTH L1

90

OUTPUT SPINDLES



BENZ Solidfix®

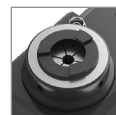

Collet chuck System ER
DIN 6499

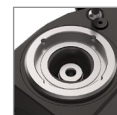

BENZ CAPTO™

i Other output spindles available upon request



BENZ Solidfix® / Collet chuck

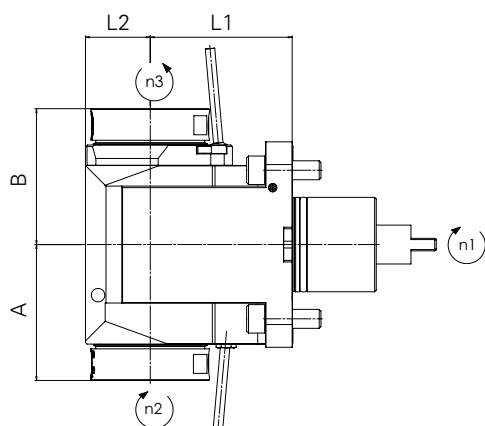
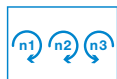

BENZ CAPTO™

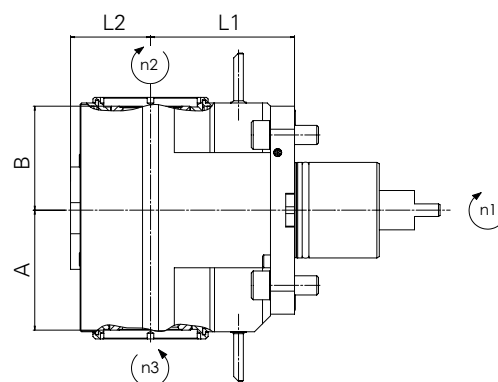
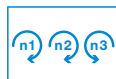

Technical data

Output spindle	Size Spindle	i	EC	IC*	$n_{1\max} / n_{2\max}$ [rpm]	$M_{1\max} / M_{2\max}$ [Nm]	A_{\max} [mm]	B [mm]	L1 [mm]	L2 [mm]	Order No.
BENZ Solidfix®	S5	1:1	✓		6000 / 6000	150 / 150	86	63	90	41	115FAX03559S52
Collet Chuck	ER40A	1:1	✓		6000 / 6000	150 / 150	81,5	63	90	41	115FAX03559E7A2
BENZ CAPTO™	C5	1:1	✓		6000 / 6000	150 / 150	80,5	70,5	90	50	115FAX03500L5BD2

*Innenkühlung $p_{\max} = 100$ bar

LIVE TOOL – BMT 60

ADJUSTABLE

TECHNICAL DATA



OUTPUT SPINDLE

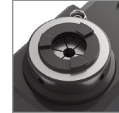

Collet chuck
System ER
DIN 6499

i Other output spindles
available upon request



Collet chuck

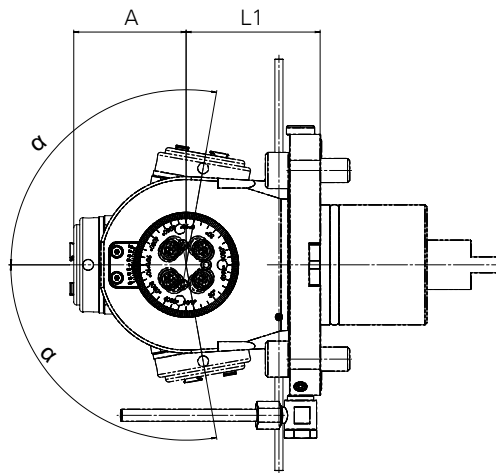

Technical data										Order No.
Output spindle	Size Spindle	i	EC	IC*	$n_{1\max} / n_{2\max}$ [rpm]	$M_{1\max} / M_{2\max}$ [Nm]	A_{\max} [mm]	L1 [mm]	α [°]	
Collet Chuck	ER25A	1:0,816	✓	-	6000 / 4900	32 / 39	57,9	67	100	115FDX03549E5A
	ER25A	1:0,816	✓	✓	6000 / 4900	32 / 39	62,9	67	100	115GDX03549E5A

*Internal cooling $p_{\max} = 50$ bar

LIVE TOOL – BMT 60

RADIAL, BROACHING UNIT - BENZ LINA 4.0

TECHNICAL DATA



LENGTH L1

90

OUTPUT SPINDLE



Prism-shaped profile
Ø 30 mm



Industry 4.0 ready
Contact the BENZ Sales Team

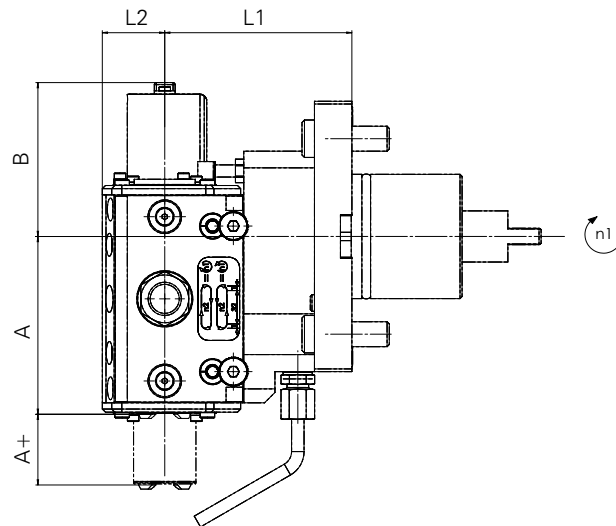

Performance data

Type	$n_{1 \max} / *n_{2 \max}$ [rpm / min ⁻¹]	$M_{1 \max} / F_{c \max}$ [Nm]	f [mm]	Groove width _{max} [mm]
GS	3000 / 1500	15 / 1700	0,02 - 0,10	12
GSL	2000 / 1000	23 / 1700	0,02 - 0,10	12

Technical Data

Type	Size Plunger	i	EC	IC	**Stroke [mm]	A [mm]	A+ [mm]	B [mm]	L1 [mm]	L2 [mm]	Order No.
GS	30	2:1	✓	✓	32	86,5	33	74	90	30	115GS03502B2D-90
GSL	30	2:1	✓	✓	51	115,5	53	87,5	90	30	115GSL03508B2D-90

*number of double stroke per minute

**usable working stroke

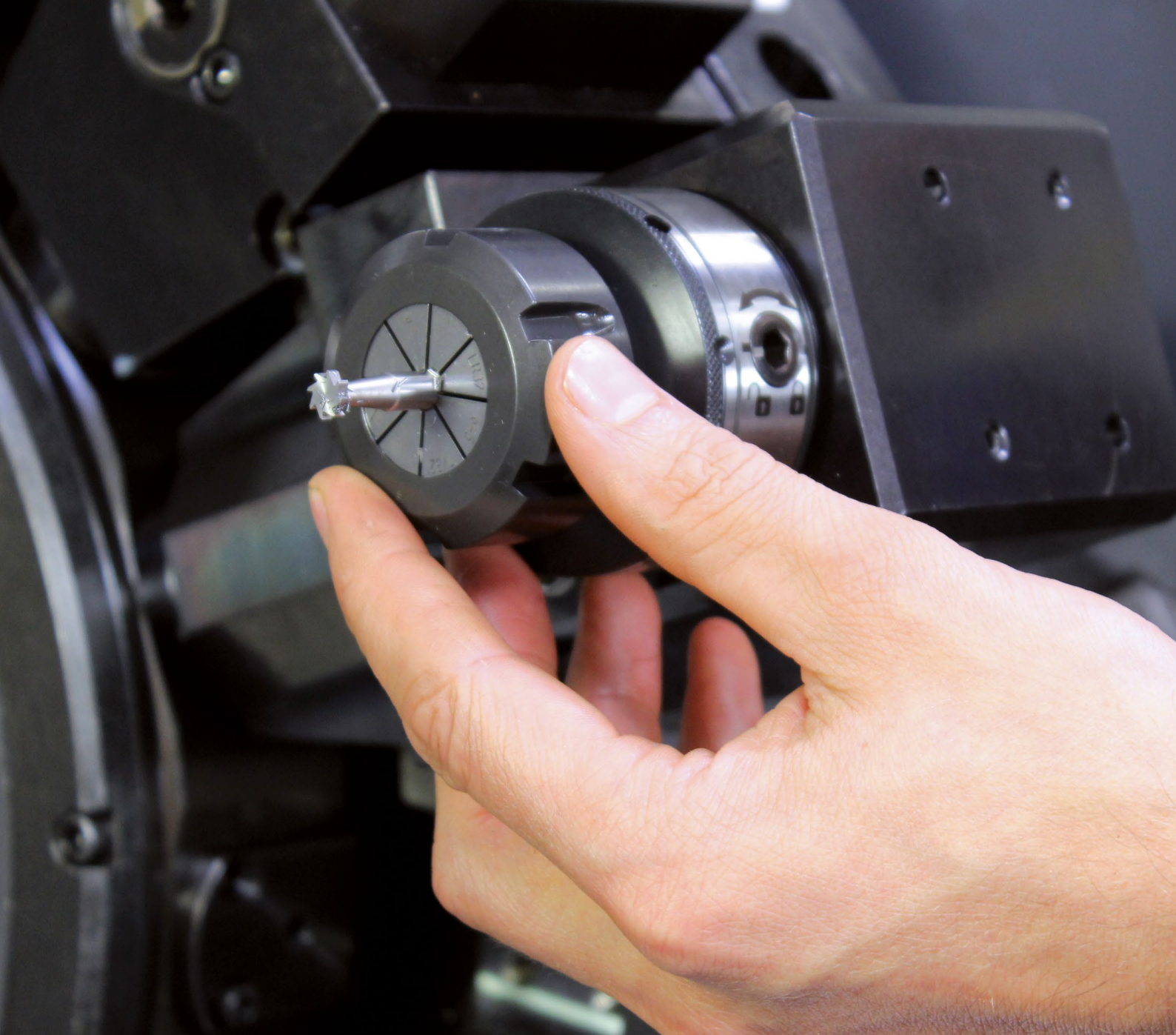

ACCESSORIES

Practical additions for your interchangeable unit

BENZ Solidfix® is a modular quick change system that allows you to change tools in less than 20 seconds. The time-consuming process of removing the live tool from the machine is avoided, as only the adapter with cutting tool is changed. Replacing

the change adapter saves you several live tools. **Your advantage:** One live tool instead of several – and therefore lower investment costs compared to exchanging the complete unit!

A large selection of adapters and matching accessories can be found in our catalogue [BENZ Modular Quick Change Systems](#)



STATIC HOLDERS – BMT 60

O.D. TURNING TOOL | SINGLE

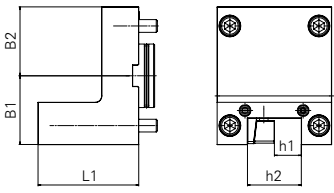
Model	Drawing	Technical data					EC	Order No.
		h1 [mm]	h2 [mm]	L1 [mm]	B1 [mm]	B2 [mm]		
		25	50	95	40	90	✓	115A035560003

O.D. TURNING TOOL | 2 TOOLS - MAIN & SUB SPINDLE

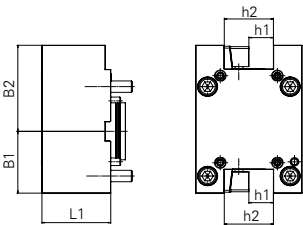
Model	Drawing	Technical data					EC	Order No.
		h1 [mm]	h2 [mm]	L1 [mm]	B1 [mm]	B2 [mm]		
		25	50	70	90,5	65	✓	115A035567001

FACE AND I.D. TURNING TOOL | SINGLE

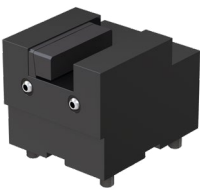
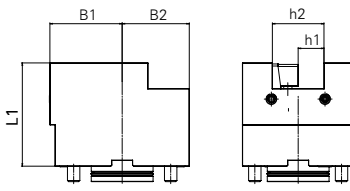
Model	Drawing	Technical data					EC	Order No.
		h1 [mm]	h2 [mm]	L1 [mm]	B1 [mm]	B2 [mm]		
		25	50	100	70	65	✓	115A035559001

BORING BAR HOLDER | SINGLE

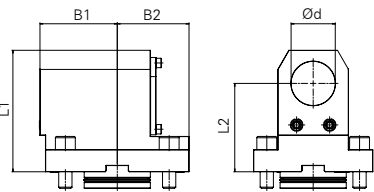
Model	Drawing	Technical data						Order No.
		Ød [mm]	L1 [mm]	L2 [mm]	B1 [mm]	B2 [mm]	EC IC	
		40	110	80	70	65	✓ ✓	115A035578001

CUT-OFF HOLDER

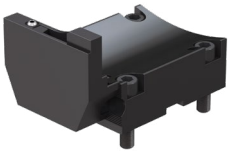
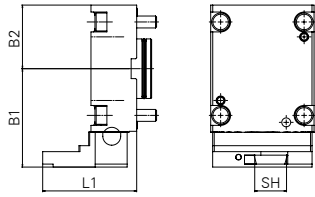
Model	Drawing	Technical data					Order No.
		SH [mm]	L1 [mm]	B1 [mm]	B2 [mm]	EC	
		32	94,6	99	65	✓	115A035583001

AXIAL HOLDER | SINGLE - BENZ CAPTO™

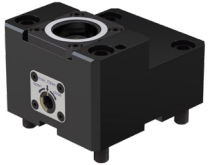
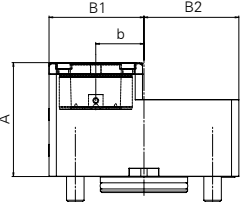
Model	Drawing	Technical data					Order No.	
		Size Adapter [mm]	A [mm]	b [mm]	B1 [mm]	B2 [mm]		IC
		C5	78	33	65	65	✓	115AV035L5BDU-78

AXIAL HALTER | 2 TOOLS - BENZ CAPTO™ - MAIN & SUB SPINDLE

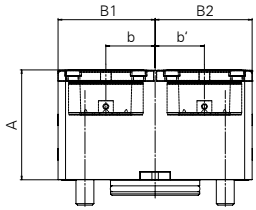
Model	Drawing	Technical data					Order No.	
		Size Adapter [mm]	A [mm]	b / b' [mm]	B1 [mm]	B2 [mm]		IC
		C5	78	33	65	65	✓	115AV035L5BD2U-78

AXIAL HALTER | 2 TOOLS - BENZ CAPTO™ Y

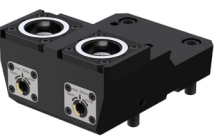
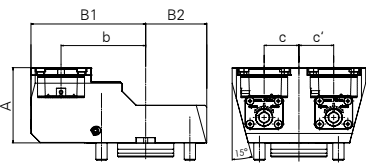
Model	Drawing	Technical data						Order No.	
		Size Adapter [mm]	A [mm]	b [mm]	B1 [mm]	B2 [mm]	c / c' [mm]		IC
		C5	80	90	122	65	37	✓	115AV035L5BS0676

STATIC HOLDERS – BMT 60

RADIAL HOLDER | SINGLE - BENZ CAPTO™

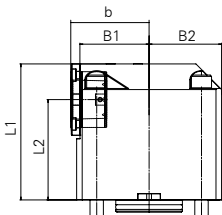
Model	Drawing	Technical data						Order No.	
		Size Adapter [mm]	L1 [mm]	L2 [mm]	b [mm]	B1 [mm]	B2 [mm]		IC
		C5	122	90	70	65	65	✓	115AP035L5BDU-90

RADIAL HOLDER | 2 TOOLS - BENZ CAPTO™ Y

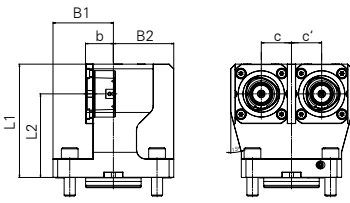
Model	Drawing	Technical data							Order No.	
		Size Adapter [mm]	L1 [mm]	L2 [mm]	b [mm]	B1 [mm]	B2 [mm]	c / c' [mm]		IC
		C5	122	90	30	65	65	32,5	✓	115AR035L5BS0750

RADIAL HOLDER | 2 TOOLS - BENZ CAPTO™ - MAIN & SUB SPINDLE

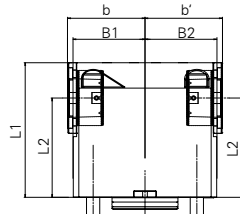
Model	Drawing	Technical data						Order No.	
		Size Adapter [mm]	L1 [mm]	L2 [mm]	b / b' [mm]	B1 [mm]	B2 [mm]		IC
		C5	122	90	70	65	65	✓	115AR035L5B2U-90

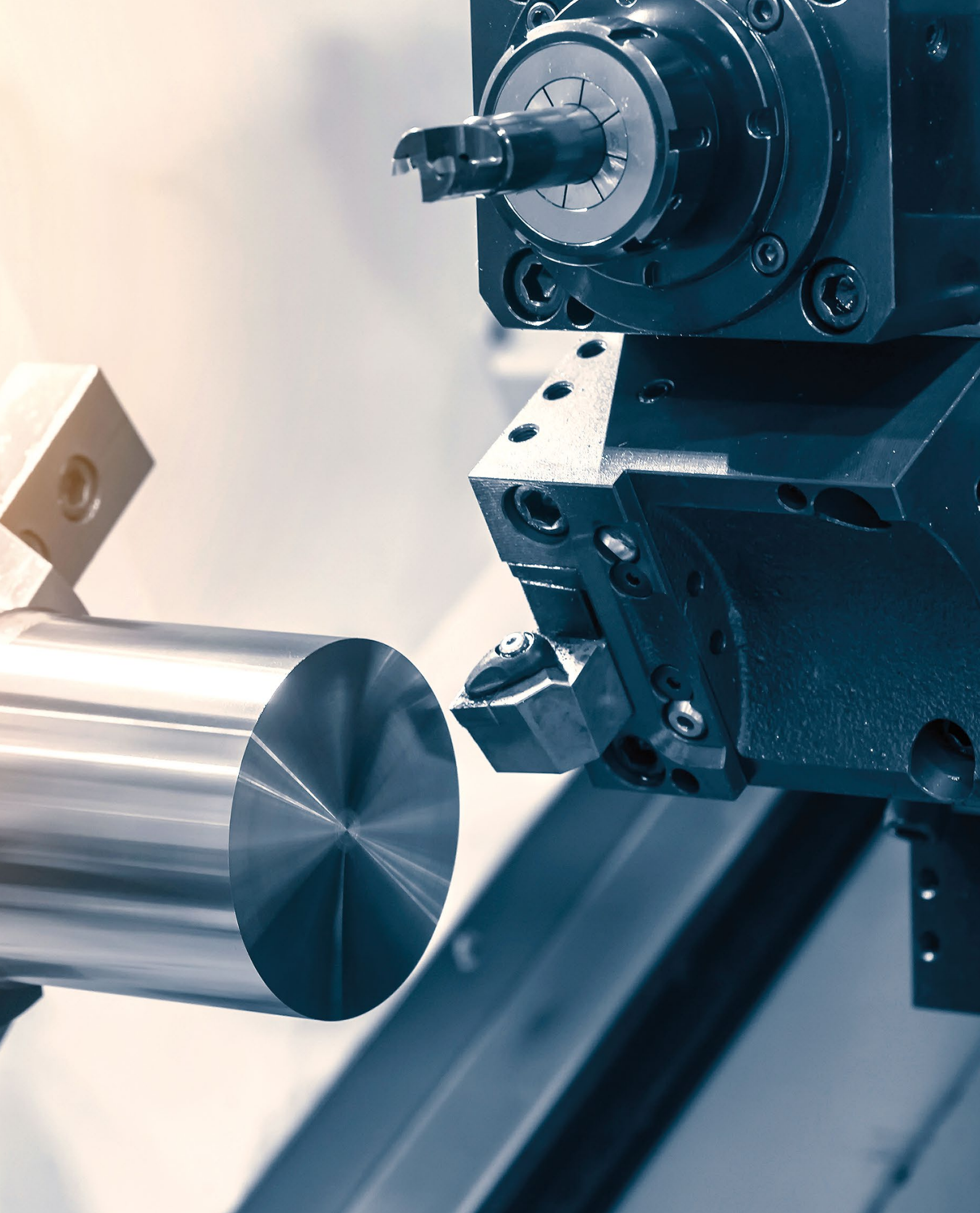

BENZ PRODUCT WORLD

TOOLING & MACHINE TOOLING TECHNOLOGY

TOOLING TECHNOLOGY



METAL

LIVE TOOLS/TOOL HOLDERS

- Radial heads 90°
- Radial heads ≠ 90°
- Axial heads
- Swivel heads
- Multi-spindle heads
- Broaching units
- Rotating tool holders
- Static tool holders

COMPONENTS. Our comprehensive tool concepts for turning centers and milling centers are ideal for nearly every application. Providing a technological advantage is our goal.

SPECIFIC TO THE CUSTOMER. Our modular approach enables customized configurations.

SYSTEMS. We develop special customer-specific tools for OEM and end customers on request.



METAL

EXCHANGEABLE UNITS

- Angle heads 90°
- Angle heads ≠ 90°
- Swivel heads
- Multi-spindle heads
- Broaching units
- High-speed spindles

KNOWLEDGE AND EXPERIENCE. Our knowledge of the metalworking industry and decades of development partnership make us ideal for new tasks anywhere in the world.

COMPONENTS. We deliver a vast array of standard components from stock and develop innovative, customized systems for OEM and end customers.

VARIETY. Whether in machining centers in the automotive, aerospace or wind energy industries, units from Benz can be used anywhere. Numerous customers choose us as their systems and innovation partner.



WOOD / COMPOSITE AND ALUMINIUM

EXCHANGEABLE UNITS

- Angle heads 90°
- Swivel heads
- Multi-spindle heads
- Multi-axis heads
- Sanding units
- Floating head units

FOR ANY APPLICATION. Cost-effectively process and machine wood, composites and aluminium: We provide series production angle heads for drilling, milling, sawing and grinding in addition to other units for special applications.

FROM BASIC TO HIGH-END. Benz units are available in a variety of performance classes, making them ideal for everything from light machining to high-performance continuous operation.

SYSTEMS. We have the solution for your special applications: Customized Benz units for machining centers. Put us to the test!

MACHINE TOOLING TECHNOLOGY

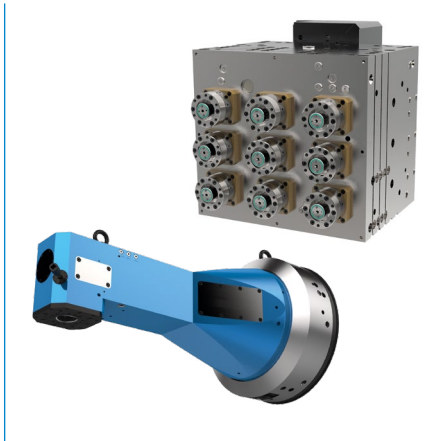

METAL

MULTI-SPINDLE HEADS AND LARGE DRILL HEADS

- Large angle heads
- Large drill heads
- XXL multi-spindle heads

DEVELOPMENT PARTNER. We accompany you from brainstorming to inspection of the final machine, always to your expectations.

Our assortment ranges from compact heads to XXL units.

SYSTEMS. Benz stands for high-end solutions in the fields of machine tooling technology, specialty solutions, custom assemblies and mechanical modules. We manufacture and configure multiple-spindle and large-angle heads as well as large drill heads.

COMPONENTS. Attachment units complete our range.

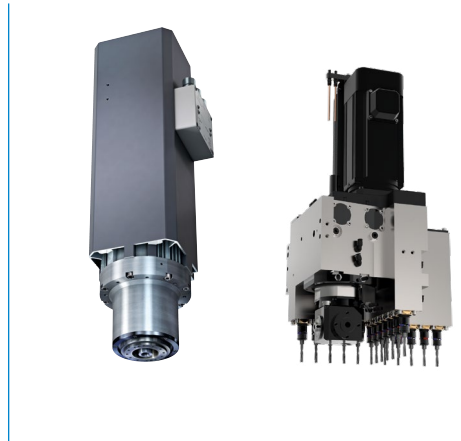

METAL / WOOD / COMPOSITE AND ALUMINIUM

SYSTEM TECHNOLOGY

- Multiple-spindle drill heads
- Motor spindles
- Motors
- 5-axis technology
- C-axes
- Swivel axes
- Rotary distributors
- Z-axes

COMPONENTS. Our range includes standard products in an assortment of shapes and sizes.

THE PERFECT ADDITION. Our system additions provide you with even more efficiency. Perfect your existing solutions with Benz products!
SYSTEMS. We develop the technology of tomorrow. Your individual requirements for the efficiency of your machine tools and the suitability of the tools in use provide our benchmark for new, innovative solutions.

SERVICE

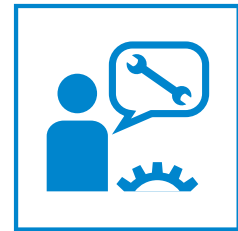

METAL / WOOD / COMPOSITE AND ALUMINIUM

SERVICE

- Repair service
- Rapid Repair Kit
- Preventive maintenance
- Spare part management
- Global service
- Service hotline

DO NOT LOSE A SECOND. Speed is the order of the day when unexpected breakdowns occur. Our service center ensures immediate assistance around the world. We ensure your machine has as little downtime as possible.

SERVICE QUALITY. We guarantee top service quality reflecting our expertise as a manufacturer.

FORESIGHT. We go one step further: Preventive maintenance, customized Rapid Repair Kits and our spare part management service ensure you have the best setup to face any emergency. We look to the future to keep you at your peak.

PICTOGRAMS & ABBREVIATIONS OVERVIEW

UNIT SPECIFICATIONS

Type of machining



Drilling

The unit is suitable for boring machining



Milling

The unit is suitable for milling machining



Threading

The unit is suitable for thread machining



Broaching and slotting

The unit is suitable for machining by broaching and slotting

Number of output spindles (tool holding fixtures)



1

The unit has one output spindle



2

The unit has two output spindles

Axis angle



0°

Unit for machining tasks at a 0° angle



90°

Unit for machining tasks at a 90° angle



± 0

Unit for machining tasks at an adjustable angle
0° ± max. α°

Drive for spindle Direction of rotation



clockwise / clockwise
synchronized rotation



clockwise / counterclockwise
counter-rotation

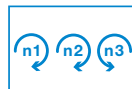

clockwise / clockwise / counterclockwise
synchronized and counterrotation

Coolant feed for cutting blade



Extern (EC)

The tool is cooled using an external feed line (spray nozzle)



Combination (EC+IC)

The tool is cooled by a combination of both internal and external systems

ABBREVIATIONS

M_{max}

Maximum torque

i

Gear ratio

n_{max}

Maximum speed

p_{max}

Maximum pressure (bar)

EC

External cooling

IC

Internal cooling

p.

Page

✓

Possible

-

Not possible

SW

Width across flats

mm

Millimeter

Usage note – general

The contents of this catalog are not legally binding and are intended solely for informational purposes. Any final agreement will be in the form of a written order confirmation from BENZ GmbH, which occurs only subject to the respective current General Terms and Conditions of Sale and Delivery of BENZ GmbH. These can be found online at www.benz-tools.de.

All of the products listed in this catalog are designed for their intended use, e.g. machines for precision machining. The recognized technical regulations for safety and professional work must be followed for use and installation.

Furthermore, the respective laws, guidelines from TÜV, guidelines from the respective trade association and VDE stipulations shall apply.

The technical data listed in this catalog must be observed by the user. The conditions of use may not fall below or exceed the specified data. If information is missing, it cannot be assumed that there are no upper or lower limits or no limitations for specific use cases. Consultation is required in these cases.

Disposal is not included in the price, which would have to be taken into account accordingly in the event of return to or disposal by BENZ GmbH.

TECHNICAL DATA AND FIGURES

The technical data and figures have been compiled with great care and to the best of our knowledge. We cannot guarantee that the information is up to date, correct or complete.

The specifications and information - such as figures, drawings, descriptions, dimensions, weights, materials, technical and other performance data and the described products and services - contained in general product descriptions, BENZ GmbH catalogs, brochures and price lists in any form are subject to change and may be modified or updated at any time without prior notification. They are binding only to the extent expressly specified in a contract or order confirmation. Slight deviations from such descriptive product information shall be considered approved and shall not affect fulfillment of agreements insofar as they are reasonable for the customer.

LIABILITY

Products from BENZ GmbH are subject to the German Product Liability Act. This catalog does not contain any guarantees, assurances of quality or procurement agreements for the products it depicts, neither expressly nor implied, including for the availability of products. Advertising statements relating to quality features, properties or applications for the products are not legally binding.

To the extent permitted by law, BENZ GmbH is exempt from any liability for direct or indirect damage, subsequent damage and requests of any kind or on any legal basis resulting from the use of information contained in this catalog.

TRADEMARK, COPYRIGHT AND REPRODUCTION

The depiction of commercial property rights in this catalog - such as brands, logos, registered trademarks or patents - does not include the granting of licenses or use rights. Their use is not permitted without the expressed written agreement of BENZ GmbH. All contents of this catalog are the intellectual property of BENZ GmbH. For the purposes of copyright, any unlawful use of intellectual property, including excerpts, is prohibited. Reprinting, copying or translating (including in the form of excerpts) are permitted only with the prior written consent of BENZ GmbH.

STANDARDS

BENZ GmbH Werkzeugsysteme has a quality management system certified in accordance with ISO 9001:2008. BENZ GmbH Werkzeugsysteme has an environmental management system certified in accordance with ISO 14001:2004.

Usage note – individual

DECLARATION OF INCORPORATION IN TERMS OF THE EC DIRECTIVE 2006/42/EC ON MACHINERY (ANNEX II 1 B)

We hereby declare that our products meet the basic requirements of the Machinery Directive 2006/42/EC as an incomplete machine to the extent that this is possible as part of delivery.

We also declare that the specific technical documents were produced in accordance with Annex VII Part B of this Directive. We undertake to provide the market supervisory bodies with versions of the incomplete machine's special documents via our documentation department should they have reason to request them.

The incomplete machine also satisfies the stipulations of EC Directive 2014/30/EU on electromagnetic compatibility. The protective goals of EC Directive 2014/35/EU regarding electronic equipment have been met.

The incomplete machine may only be commissioned if it has been ascertained, if applicable, that the machine or system in which the incomplete machine is to be installed satisfies the requirements of Directive 2006/42/EC on Machinery and an EC declaration of conformity has been drawn up in accordance with Annex II.

This catalogue was issued with great care and all specifications were checked for correctness. However, no liability is assumed for incorrect or incomplete information. BENZ GmbH Werkzeugsysteme reserves the right to make technical changes and improvements through continual further development of the products and services. All texts, images, representations and drawings in this catalogue are the property of BENZ GmbH Werkzeugsysteme

and are protected by copyright. Any kind of reproduction, editing, modification, translation, filming or processing and saving in electronic systems is prohibited without the consent of BENZ GmbH Werkzeugsysteme.

The contents and data are valid at the time of printing. Edition 01/2024

BENZ GmbH Werkzeugsysteme

Kinzigpark 3
77723 Gengenbach
Germany

T +49 7803 504 300-0
info@benztooling.com
www.benztooling.com

