

BENZ SPEEDTEC HIGH-SPEED SPINDLES

Tooling technology

Metal machining

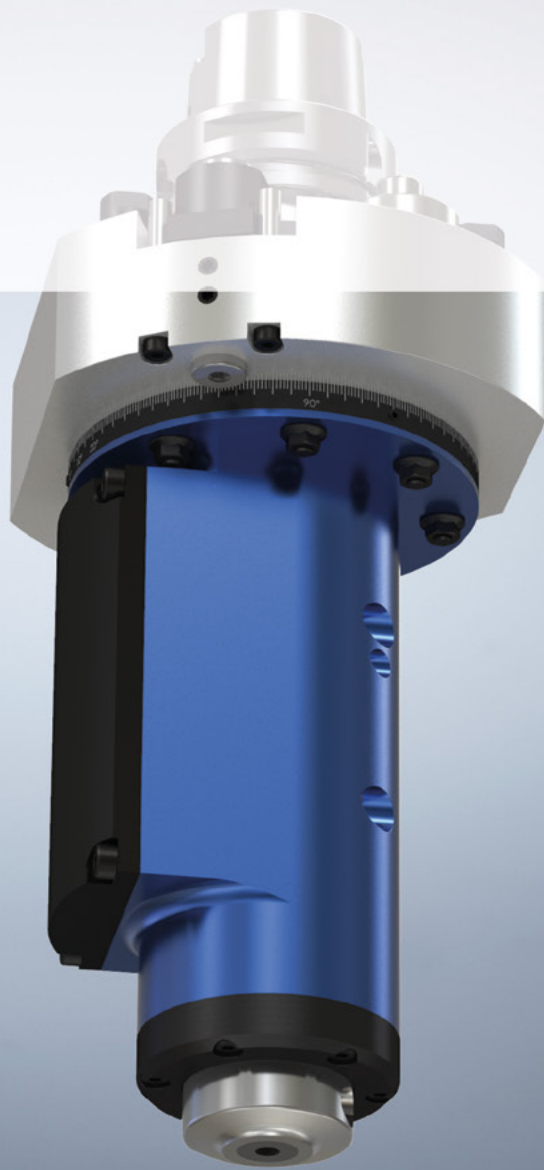

BENZ SPEEDTEC HIGH-SPEED SPINDLES

BENZ EXCHANGEABLE UNITS FOR LIGHT MACHINING OPERATIONS

BENZ High-speed spindles are used when the spindle speed of a machine and the resulting cutting speed is not sufficient for machining, which is often the case with older machine types.

In „BENZ SPEEDER“ products, the speed transmission is mechanical. For „BENZ JET“ products, the transmission is coolant-driven.

The extensive of possible applications for the „SPEEDTEC SERIES“ is wide-ranging in the field of drilling and light milling applications.

BENZ SPEEDER

BENZ Speeder – High-speed spindles use standard mechanical gear technology.

A maximum output speed of up to 40,000 rpm is generated from the input speed of the machine, where the gear ratio is 1:5.

The high-speed spindle is equipped with jacket cooling as standard and can optionally be operated with an internal coolant supply up to a maximum of 100 bar. The special bearing and sealing technology ensure lower heat buildup, which guarantees dimensional stability during longer machining cycles.

BENEFITS

Reduces production time – protects the machine

- + high speed ranges
- + high dimensional stability even with longer machining cycles
- + excellent running smoothness and run-out accuracy
- + low heat buildup

BENZ SPEEDER

Features

- + precise drilling operations
- + clamping-Ø* 2.0 mm - 34.0 mm
- + low heat buildup due to jacket cooling

Possible machining operations

- + drilling, engraving, chamfering, deburring



BENZ SPEEDER-HD

Features

- + precise milling operations with clamping-Ø of 6.0 mm
- + high speed ranges

Possible machining operations

- + milling*, drilling, engraving, chamfering, deburring



* depending on model size

* milling machining requires a three-point support

BENZ JET

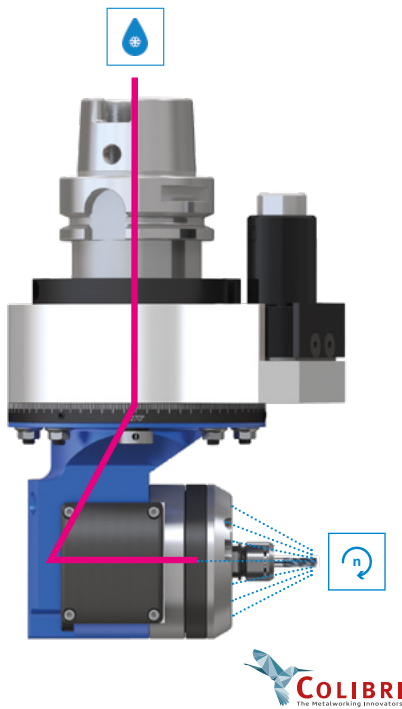

BENZ Jet – High-speed spindles use HPC spindle technology developed and provided by Colibri Spindles.

The spindle is driven by the central coolant supply of the machine spindle and is therefore appropriate for machines with high coolant pressure. The use of this technology guarantees optimized machining results, increased process efficiency and a 70% reduction in machining time.

The high-speed spindle is ready for use in a very short time by using a standard tool system (ER11 collet chuck).

BENEFITS

Reduced production time as a result of

- + high speed ranges
- + high dimensional stability even with longer machining cycles
- + excellent running smoothness and run-out accuracy
- + plug & play: commissioning in a very short time
- + real-time wireless speed monitoring via external display



OPTIONS

BENZ Jet Angle head without torque support

- + fast commissioning
- + accuracy depending on the drive cone
- + stop block not necessary

BENZ Jet Angle head with torque support

- + highest precision
- + stop block necessary

BENZ JET-AXIAL

Features

- + precise drilling operations with \varnothing 0.5 mm - \varnothing 3.0 mm and milling operations with a \varnothing 1.0 mm - \varnothing 4.0 mm

Possible machining operations

- + pre-machining and finishing, drilling, milling, chamfering



BENZ JET-RADIAL (90°)

Features

- + precise drilling operations with \varnothing 0.5 mm - \varnothing 3.0 mm and milling operations with a \varnothing 1.0 mm - \varnothing 4.0 mm

Possible machining operations

- + pre-machining and finishing, drilling, milling, chamfering



BENZ GmbH Werkzeugsysteme

Im Mühlegrün 12
D-77716 Haslach
T +49 7832 704-0
F +49 7832 704-8001
info@benztooling.com
www.benztooling.com

